



BULL OUTDOOR PRODUCTS

46 INCH ROTISSERIE KIT

OWNER'S MANUAL

SKU# 66000

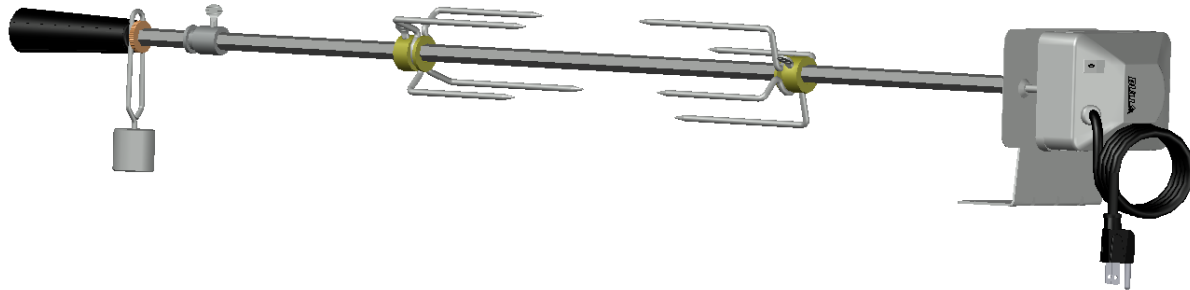

We care about your safety, so please

READ THIS ENTIRE MANUAL CAREFULLY AND RETAIN FOR FUTURE REFERENCE.

- THIS ROTISSERIE KIT INTENDED FOR USE ONLY FOR BULL GRILLS.
- FOLLOW YOUR GRILLS INSTRUCTIONS FOR ROTISSERIE USE.
- BE SURE YOUR ROTISSERIE IS PROPERLY INSTALLED TO YOUR GRILL.
- FOLLOW INSTRUCTIONS FOR USE TO AVOID DAMAGING ROTISSERIE.
- IF YOU HAVE QUESTIONS CONCERNING ASSEMBLY OR OPERATION, CONSULT YOUR DEALER.
- NOTE TO INSTALLER: LEAVE THESE INSTRUCTIONS WITH THE CONSUMER AFTER INSTALLATION.



USA EDITION

TABLE OF CONTENTS	PAGE #
REGISTERING YOUR ROTISSERIE / REPLACEMENT PART ORDERING	2
INSTALLATION /	3
OPERATION / SAFETY / USAGE OPTIONS	4
WARRANTY POLICY	5-7

FOR WARRANTY PURPOSES, PLEASE RECORD YOUR MODEL NUMBER, SERIAL NUMBER, DATE OF PURCHASE USING THE PRODUCT INFORMATION CARD PROVIDED ON PAGE AND A COPY OF YOUR RECEIPT AND OR INVOICE.

⚠ WARNING: THIS PRODUCT CAN EXPOSE YOU TO CHEMICALS INCLUDING CARBON MONOXIDE, WHICH IS KNOWN TO THE STATE OF CALIFORNIA TO CAUSE BIRTH DEFECTS OR OTHER REPRODUCTIVE HARM. FOR MORE INFORMATION VISIT www.P65Warnings.ca.gov **⚠**

WARNING: Fuels used in gas or oil-fired appliances and the products of combustion of such fuels, contain chemicals known to the State of California to cause cancer, birth defects and/or reproductive harm. This warning is issued pursuant to California Health & Safety Code Sec. 25249.6.

V2025.09.02



Warranty Questions call Customer Service at
(800) 521-2855

PRODUCT WARRANTY AND REGISTRATION

THANK YOU FOR CHOOSING BULL OUTDOOR PRODUCTS. TO ENABLE OUR COMMITMENT TO YOUR SATISFACTION, YOU WILL NEED TO REGISTER YOUR PURCHASE FOR IT TO BE COVERED UNDER BULL'S WARRANTY POLICY. PLEASE SAVE YOUR PURCHASE RECEIPT AS IT IS REQUIRED FOR WARRANTY CLAIMS. ADDITIONALLY, REGISTERING YOUR PURCHASE WILL ALLOW YOUR BULL AUTHORIZED DEALER TO UTILIZE THE ENCODED INFORMATION FOR THE PURPOSE OF ORDERING REPLACEMENT PARTS OR ADDITIONAL ACCESSORIES TO ENSURE YOUR PURCHASE REMAINS IN OPTIMAL WORKING CONDITION. TO VALIDATE YOUR WARRANTY, WE OFFER TWO OPTIONS AS SHOWN BELOW:

OPTION 1 / REGISTERING ONLINE

REGISTRATION CAN BE COMPLETED ON THE BULL CUSTOMER SERVICE PORTAL, FOUND AT <https://api.bullbbq.com/c/>

OPTION 2 / REGISTERING BY MAIL

COMPLETE THE PRODUCT WARRANTY REGISTRATION CARD THAT WILL BE IN THE SHIPPING BOX (SEE REFERENCE)

SEND TO: BULL OUTDOOR PRODUCTS, INC.
15 EAST AVE. ATHENS, TN 37303

ATTN: WARRANTY SERVICE CENTER
UNPACKING THE SHIPPING BOX

GO TO <https://bullbbq.com/bull-support-videos/> WHERE WE SHOW YOU HOW TO UNBOX, INSTALL COMPONENTS, AND MORE.

AFTER OPENING THE SHIPPING BOX, INSPECT THE CONTENTS FOR ANY DAMAGE AND CONTACT OUR SERVICE CENTER OR LOCAL DEALER FOR THE REPLACEMENT OF ANY DAMAGED PARTS. IF DAMAGED **DO NOT** ATTEMPT INSTALLATION.

MODEL NUMBER LOCATION FOR ROTISSERIE MOTOR

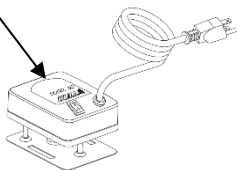

Bull Outdoor Products Warranty Registration Card

Name _____ Date of Purchase _____

Place of Purchase _____

Email Address _____ Phone _____

Street Address _____ Apt # _____

City _____ State _____ Zip Code _____

How To Register
On Our Website: <https://api.bullbba.com/c/>
Via Mail: Fill out this form and mail it to us!

Model Name: _____
Model Number: _____
Serial Number: _____

Scan This Code With Your Phone:

MODEL AND SERIAL NUMBER LOCATIONS ON SHIPPING BOX

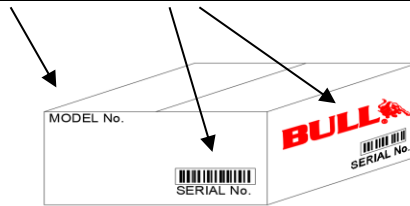

ORDERING REPLACEMENT PARTS

PLEASE REFER TO YOUR OWNER'S MANUAL PARTS LIST AND ILLUSTRATION TO IDENTIFY WHAT YOU NEED. BELOW ARE OPTIONS FOR ORDERING, IF YOU HAVE NOT YET REGISTERED YOUR PURCHASE, PLEASE REGISTER ON OUR WEBSITE AS SOON AS POSSIBLE AS THIS INFORMATION IS ESSENTIAL FOR ORDERING REPLACEMENTS.

TO ORDER REPLACEMENT PARTS ONLINE

GO TO: <https://bullbbq.com/buy-parts>

TO ORDER REPLACEMENT PARTS BY PHONE

WE HAVE TWO AUTHORIZED PARTS DISTRIBUTORS READY TO ASSIST.

Western Region
(800)258-6810

Eastern Region
(800)229-3056

BULL SKU# 66000 46 INCH ROTISSERIE SYSTEM REPLACEMENT PARTS LIST AND ILLUSTRATION

REF #	PARTS #	DESCRIPTION	QTY
1	16552	110 VAC MOTOR W/SWITCH	1
2	16554	MOTOR MOUNT BRACKET	1
3	62710	DIABLO ROTISSERIE ROD	1
4	62714	LARGE 4-PRONG SPIT FORK	2
5	16587	1/4-20 X 1/2 THUMBSCREW	3
6	62715	SHAFT COLLAR	1
7	16675	THREADED SPACER	1
8	16586	COUNTER BALANCE	1
9	16585	BLACK HANDLE	1

WARRANTY IS 1 YEAR FOR ALL PARTS

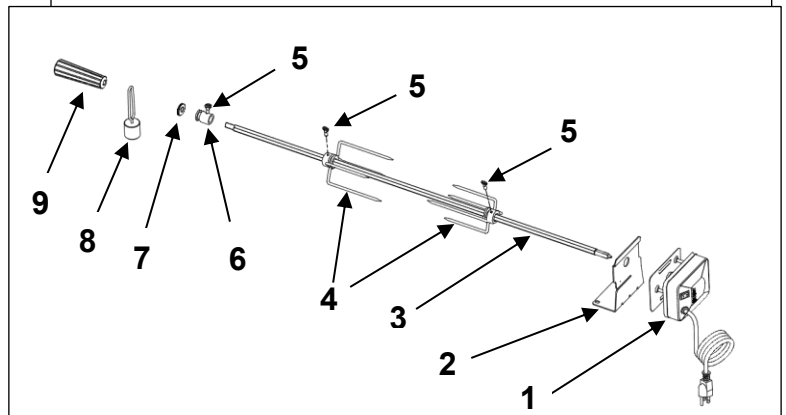

WARNING: USE OF ANY PART THAT IS NOT FACTORY AUTHORIZED WILL VOID YOUR WARRANTY AND MAY BE DANGEROUS.



ROTISSERIE KIT INSTALLATION

WARNING DO NOT INSTALL ROTISSERIE KIT WHILE USING GRILL. INSTALL BEFORE USING OR WAIT FOR GRILL TO BE COOL ENOUGH TO TOUCH.

INSTRUCTIONS:

- 1) OPEN GRILL AND REMOVE THE WARMING RACK.
- 2) USE THESE SCREWS TO ATTACH BRACKET.

Note: The motor bracket can be mounted on either side of the grill. If you have a side burner next to your grill mount the bracket on the opposite side.

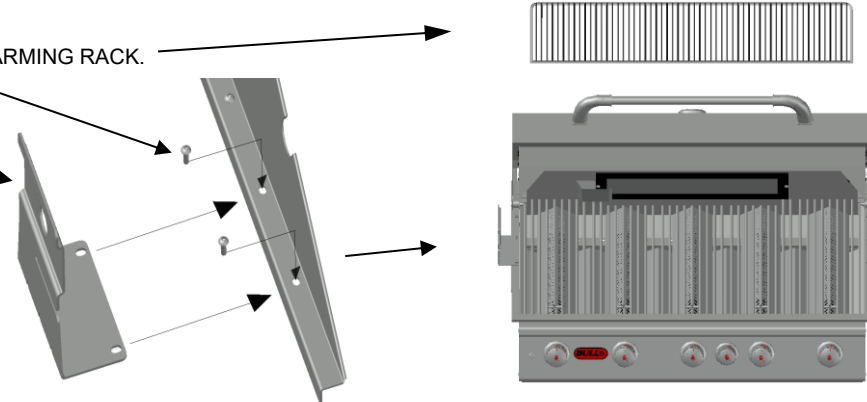

- 3) ADD PARTS TO SPIT ROD PER REFERENCE DRAWING.

STEP ONE: (LOCATE THE SPIT FORKS AND SHAFT COLLAR PER DRAWING, DIMENSIONS ARE IN INCHES.)

STEP TWO: INSTALL SPACER, COUNTER BALANCE AND HANDLE ON TO THE THREADED END OF SPIT ROD.

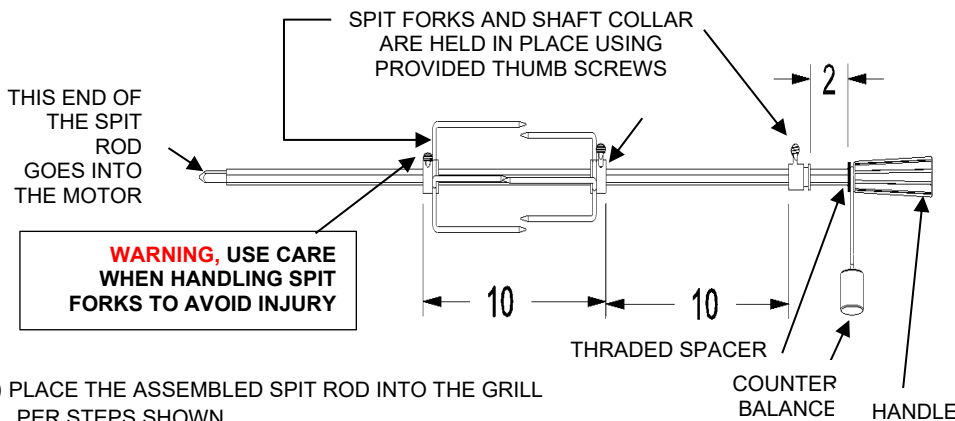

NOTE: LINE THUMB SCREWS UP TO FLAT ON SPIT ROD AS SHOWN BEFORE TIGHTENING.

WARNING, USE CARE WHEN HANDLING SPIT FORKS TO AVOID INJURY

- 4) PLACE THE ASSEMBLED SPIT ROD INTO THE GRILL PER STEPS SHOWN.

STEP ONE: SLIDE MOTOR ON TO BRACKET.

STEP TWO: TAKE THE ASSEMBLED SPIT ROD AND INSERT THE SQUARE END INTO THE SQUARE HOLE ON THE MOTOR.

STEP THREE: PLACE THE OTHER END OF THE SPIT IS HELD TO THE GRILL USING THE GROOVE ON THE SHAFT COLLAR SHOULD BE RESTING ON THE KNOTCH SHOWN ON THE GRILL. THUMB SCREW SHOULD BE INSIDE GRILL PER DETAIL.

STEP FOUR: TURN ON MOTOR AND CHECK THE ALIGNMENT TO MAKE SURE THE SHAFT COLLAR GROOVE IS SPINNING FREELY. BEFORE USE.

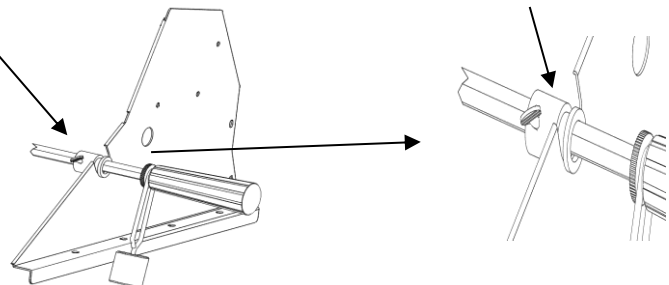
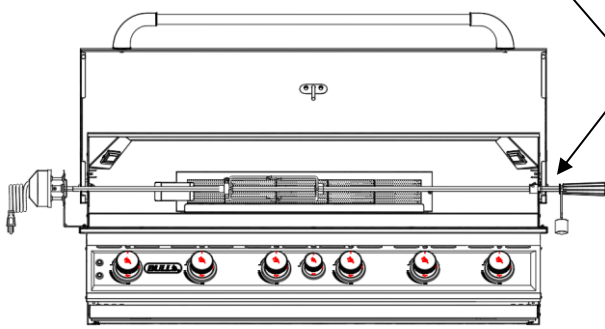
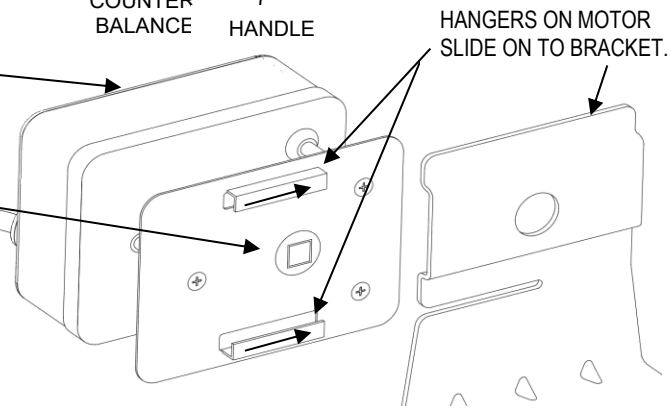



ROTISSERIE SYSTEM / COUNTERWEIGHT ADJUSTMENT

1) TO ADJUST THE COUNTERWEIGHT, LOOSEN THE BLACK HANDLE AND SLIDE THE COUNTERWEIGHT UP OR DOWN TO PROPERLY POSITION THE WEIGHT OF THE FOOD BEING COOKED. THE PURPOSE OF THE COUNTERWEIGHT IS TO BALANCE THE ROTATION AND PREVENT LOPSIDED MOVEMENT OF THE MOTOR.

ROTISSERIE SYSTEM / SAFETY

NOTE: FOLLOWING THE GUIDELINES BELOW WILL PREVENT STRAINING YOUR ROTISSERIE SPIT ROD AND MOTOR

- 1) **DO NOT** EXCEED 20 lb. MAX WEIGHT CAPACITY
- 2) THE ITEM YOUR PREPARING NEEDS TO BE PLACED IN A BALANCED POSITION ON THE ROTISSERIE SPIT ROD.
- 3) BEFORE LIGHTING THE INFRARED BURNER CHECK TO MAKE SURE THE MEAT DOES NOT HIT THE INFRARED BURNER WHILE TURNING.
- 4) **WARNING:** NEVER OPERATE INFRARED BACK BURNER AND MAIN BURNER(S) AT THE SAME TIME
- 5) WARMING RACK MUST BE REMOVED WHEN OPERATING THE ROTISSERIE BURNER

ROTISSERIE COOKING OPTIONS

SINCE INDIRECT HEAT IS OFTEN USED IN COOKING ON A ROTISSERIE, A FOIL OR ALUMINUM DRIP PAN IS ADVISABLE TO PREVENT EXCESSIVE FLARE-UPS. IF MORE SPACE IS NEEDED WHEN USING THE ROTISSERIE, REMOVE THE COOKING GRATES AND PLACE THE DRIP PAN ON THE FLAME TAMERS. YOU MAY WISH TO ADD BEER, WINE OR WATER TO THE PAN. YOUR BULL DEALER HAS DRIP PANS SPECIFICALLY FOR YOUR 30-INCH GRILL NEEDS.

COOKING WITH DIRECT HEAT

ROTISSERIE IS A GREAT METHOD FOR COOKING MEAT OR POULTRY PIECES SLOWLY AND EVENLY. THE CONSTANT TURNING PROVIDES A SELF-BASTING ACTION, MAKING FOOD COOKED ON A ROTISSERIE EXCEPTIONALLY MOIST AND JUICY. ROTISSERIE COOKING REQUIRES 1 ROTISSERIE IS MOSTLY USED TO COOK LARGE PIECES OF MEAT AND POULTRY TO ASSURE SLOW, EVEN COOKING. THE CONSTANT TURNING PROVIDES A SELF-BASTING ACTION, MAKING FOOD COOKED ON A ROTISSERIE EXCEPTIONALLY MOIST AND JUICY. ROTISSERIE COOKING GENERALLY REQUIRES 1 ½ TO 4 ½ HRS. TO COOK DEPENDING ON THE SIZE AND TYPE OF MEAT BEING COOKED.

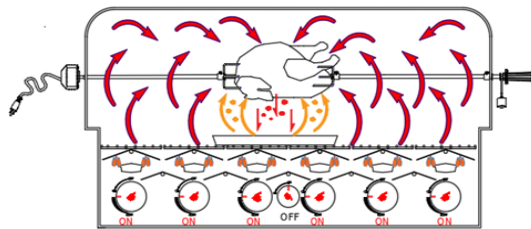

ROTISSERIE COOKING WITH DIRECT HEAT
USING MAIN BURNERS ONLY

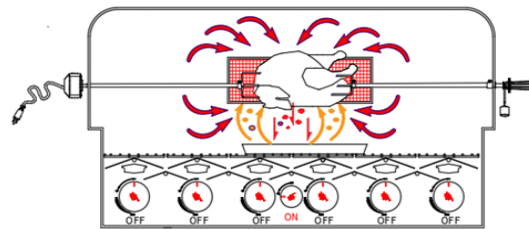

ROTISSERIE COOKING WITH DIRECT HEAT
USING INFRARED BACK BURNER ONLY

COOKING WITH INDIRECT HEAT

SINCE INDIRECT HEAT IS OFTEN USED IN COOKING ON A ROTISSERIE, A FOIL OR ALUMINUM DRIP PAN IS ADVISABLE TO PREVENT EXCESSIVE FLARE-UPS. GENERALLY, THE COOKING GRATES ARE REMOVED TO ALLOW FOR THE SWING OF THE ROTISSERIE. A BASTING PAN CAN BE PLACED UNDER THE ROTISSERIE AREA ON TOP OF THE FLAME TAMER(S) TO CATCH THE DRIPPINGS

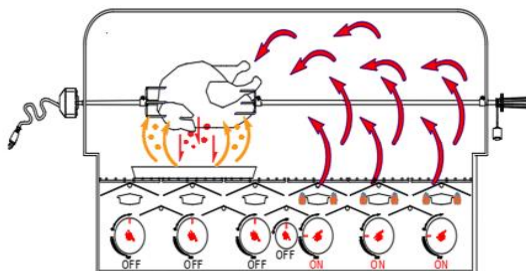

ROTISSERIE COOKING WITH INDIRECT HEAT
USING MAIN BURNERS ONLY

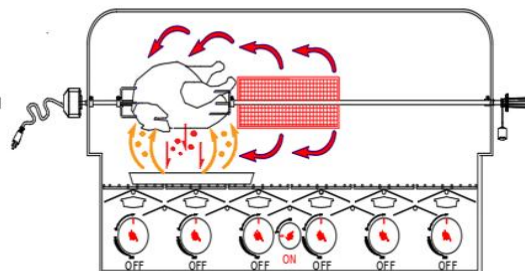

ROTISSERIE COOKING WITH INDIRECT HEAT
USING INFRARED BACK BURNER ONLY

YOU CAN COOK POULTRY AND LARGE CUTS OF MEAT SLOWLY TO PERFECTION ON ONE SIDE OF THE GRILL BY INDIRECT HEAT FROM THE NEXT BURNER OR WITH INFRARED ROTISSERIE BURNER. THE HEAT FROM THE LIGHTED BURNER CIRCULATES GENTLY THROUGHOUT THE GRILL, COOKING THE MEAT OR POULTRY WITHOUT ANY DIRECT FLAME BENEATH OR BELOW THE FOOD YOU ARE PREPARING. THIS METHOD GREATLY REDUCES FLARE-UPS WHEN COOKING EXTRA FATTY CUTS, BECAUSE THERE IS NO DIRECT FLAME TO IGNITE THE FATS AND JUICES THAT DRIP DOWN DURING COOKING. PLACE A DRIP PAN SLIGHTLY SMALLER THAN THE CUT OF MEAT ON THE COOKING GRIDS OR FLAME TAMER SURFACE UNDER THE MEAT BEING COOKED. THIS WILL ALLOW YOU TO CATCH MEAT JUICES FOR MAKING GRAVY.



Warranty Policy

LIMITED WARRANTY ON BULL OUTDOOR PRODUCTS, INC., PRODUCTS

THIS LIMITED WARRANTY GIVES YOU SPECIFIC LEGAL RIGHTS. YOU MAY ALSO HAVE OTHER RIGHTS, WHICH VARY FROM STATE TO STATE.

THIS LIMITED WARRANTY CAN ALSO BE FOUND ON OUR WEBSITE AT:

<https://www.bullbbq.com/support-warranty> (United States Customers)

<https://www.bullbbq.eu/customer-care/#warranty-registration-form> (International Customers)

AND IN THE OWNER'S/INSTALLATION MANUALS THAT WE PROVIDE WITH OUR PRODUCT

THIS LIMITED WARRANTY IS SUBJECT TO THE EXCLUSIONS, CONDITIONS AND LIMITATIONS SET FORTH BELOW.

ANY IMPLIED WARRANTIES IMPOSED BY LAW, INCLUDING WITHOUT LIMITATION TO THE IMPLIED WARRANTIES OF MERCHANTABILITY AND FITNESS FOR A PARTICULAR PURPOSE, ARE LIMITED IN DURATION TO THE DURATION OF THIS EXPRESSED LIMITED WARRANTY. SOME STATES DO NOT ALLOW LIMITATIONS ON HOW LONG AN IMPLIED WARRANTY LASTS, SO THE ABOVE LIMITATION MAY NOT APPLY TO YOU.

WHO MAY USE THIS WARRANTY?

BULL OUTDOOR PRODUCTS, INC. located at address 15 East Ave. Athens, TN 37303

("We") extend this limited warranty only to the consumer who originally purchased the product ("you") at the original site of delivery or installation. It does not extend to any subsequent owner or other transferee of the product. It does not extend to any rental, commercial, or non-residential application. Examples of excluded applications include, but are not limited to day care centers, schools, bed and breakfast centers, churches, private clubs, fire stations, club houses, Common areas in multi-family dwellings, restaurants, hotels, nursing homes, food service locations, and institutional food service locations.

WHAT DOES THIS WARRANTY COVER?

This limited warranty covers defects in materials and workmanship of the product and product components identified below for the Warranty Periods defined below.

WHAT IS THE PERIOD OF COVERAGE?

This limited warranty starts on the date of your purchase and lasts for the time periods specified on the next page. The Warranty Period is not extended if we replace the product. We may change the availability of this warranty at our discretion, but any changes will not be retroactive.



Warranty Policy (Continued)

Grilling/Pizza Accessories and Grill Covers DO NOT include a warranty period

Grill Warranty Periods

The following parts are covered for **1 year** on all our current gas grill models:

- The lid, control panel, grease tray, bezels, knobs, temperature gauge, valves, regulator, flex tubes, rotisserie burner, transformer, and all components of the lighting system.

The following parts are covered for **3 years** on all our current gas grill models:

- The manifold, handle end caps, flame tamers, heat shields, and warming rack.

The following parts are covered for the **Lifetime** on all our current gas grill models:

- Insert assembly and the grates.

The warranty period for the grill burners varies by type:

- Cast stainless steel burners - **Lifetime**
- Welded stainless steel burners - **5 years**
- Porcelain coated burners - **3 years**

The warranty period for the charcoal grill is **1 year** on all parts, except for the insert assembly, which is covered for **5 years**.

Component Warranty Periods

All the parts for our components /grill carts/refrigerators/kegerators/drawers/doors/refrigerator frames/grill jackets/finishing frames/ice chest/sinks/bar center and vent hoods are covered for **1 year** with these exceptions:

- **Power Burner**
 - The insert/grates are **lifetime** covered parts.
 - The manifold/burner are covered for **3 years**.
- **Searing Station/Slide in Double Sideburner**
 - The grates are covered for **lifetime**,
 - The insert for **5 years**, and
 - The manifold for **3 years**.
- **Single Sideburner**
 - The grates are covered for **5 years** and
 - The burner for **3 years**.
- **Sidekick**
 - The burner is covered for **3 years**.
- **Heaters**
 - The heater replacement parts are covered for **3 years**.
- **Pizza Ovens/Islands/Fire Features Warranty Periods**
 - All of the parts and construction materials are covered for **1 year**.



Warranty Policy (Continued)

WHAT DOES THIS WARRANTY NOT COVER?

This limited warranty does not cover any damage due to:

- Transportation.
- Storage
- Improper installation or use.
- Use on improper fuel/gas supply.
- Failure to follow the product instructions or to perform any preventive maintenance.
- Modifications.
- Normal wear and tear, rust, corrosion, oxidation, or discoloration.
- External causes such as accidents, abuse, or other actions or events beyond our reasonable control.

WHAT OPTIONS ARE OFFERED BY BULL OUTDOOR PRODUCTS UNDER THIS WARRANTY?

With respect to any defective product claim made during the Warranty Period, we will, in our sole discretion:

- Replace such product (or the defective part) free of charge.

WHAT IS EXCLUDED BY BULL OUTDOOR PRODUCTS UNDER THIS WARRANTY?

- We will not pay for shipping charges for replacement parts, or for any labor or labor related charges.
- We will not pay for any accessory products or ancillary products purchased by you for use in connection with the product.

HOW DO YOU NOTIFY BULL CUSTOMER SERVICE OF A POTENTIAL WARRANTY ISSUE?

Our Customer Service is ready to help. Here's how to reach us:



By Phone (800) 521-2855 Monday through Friday from 8:00 a.m. to 5:00 p.m. (EDT)



To submit a warranty, claim on-line or message go to <https://www.bullbbq.com/support-warranty.com>

LIMITATION OF LIABILITY

THE REMEDIES DESCRIBED ABOVE ARE YOUR SOLE AND EXCLUSIVE REMEDIES AND OUR ENTIRE LIABILITY FOR ANY BREACH OF THIS LIMITED WARRANTY. OUR LIABILITY SHALL UNDER NO CIRCUMSTANCES EXCEED THE ACTUAL AMOUNT PAID BY YOU FOR THE DEFECTIVE PRODUCT, NOR SHALL WE UNDER ANY CIRCUMSTANCES BE LIABLE FOR ANY CONSEQUENTIAL, INCIDENTAL, SPECIAL OR PUNITIVE DAMAGES OR LOSSES, WHETHER DIRECT OR INDIRECT.

SOME STATES DO NOT ALLOW THE EXCLUSION OR LIMITATION OF INCIDENTAL OR CONSEQUENTIAL DAMAGES, SO THE ABOVE LIMITATION OR EXCLUSION MAY NOT APPLY TO YOU.

v2025.02.14