



15 East Avenue Athens, TN 37303

(800) 521-2855

[bullbbq.com](http://bullbbq.com)

# Power Burner

Owner's Manual

SKU# 96000 LIQUID PROPANE (LP)

SKU# 96001 NATURAL GAS (NG)



**USA  
EDITION**



## Important Safety Warnings

This appliance is FOR OUTDOOR USE ONLY. This appliance must not be used in a building, garage, or any other enclosed area.

**WARNING:** This appliance is not intended to be installed in or on a boat or recreational vehicle.

**WARNING:** Ensure that your Power Burner is properly installed, assembled, and maintained. Failure to adhere to these accompanying instructions may result in fire or explosion, causing serious bodily injury or death, and/or property damage.

### **DANGER**

#### **If you smell gas:**

- **Shut off gas to the appliance.**
- **Extinguish any open flame.**
- **Open Lid.**
- **If odor continues, keep away from the appliance and immediately call your gas supplier or your fire department.**

### **WARNING**

- **Do not store or use gasoline or other flammable liquids or vapors in the vicinity of this or any other appliance.**
- **An LP cylinder not connected for use shall not be stored in the vicinity of this or any other appliance.**

 **WARNING:** This product may expose you to chemicals including lead which is known to the State of California to cause birth defects or other reproductive harm.  
For more information, visit: [www.P65Warnings.ca.gov](http://www.P65Warnings.ca.gov)

**IMPORTANT:** Installation of this appliance must conform to local codes. In the absence of local codes, installation must conform to one of the following:

- ANSI Z223.1/NFPA 54
- CSA B149.1
- CSA B149.2

**We care about your safety, so please...**

**Read and follow all warnings and instructions before assembling and cooking with your grill.**

**Retain this manual for future reference.**



## **Table of Contents**

<i>Power Burner Operational Safety</i>	4
<i>Liquid Propane (LP) Safety Guidelines</i>	5
<i>Liquid Propane (LP) Gas Requirements</i>	6
<i>Natural Gas (NG) Requirements</i>	7
<i>Checking for Gas Leaks</i>	8
<i>Determining the Location of the Power Burner</i>	9
<i>Power Burner Enclosure Requirements</i>	10
<i>Lighting the Power Burner</i>	12
<i>Burner Flames</i>	13
<i>Burner Maintenance</i>	14
<i>Burner Installation</i>	18
<i>Cleaning the Power Burner</i>	19
<i>Troubleshooting</i>	20
<i>Product Warranty and Registration</i>	22
<i>Replacement Parts List</i>	23
<i>Warranty Policy</i>	24

## **Service Information**

Model Number:

96000 (LP)

96001 (NG)

Serial Number: \_\_\_\_\_

Date of Purchase: \_\_\_\_\_

Place of Purchase: \_\_\_\_\_

Fuel Type:

Liquid Propane (LP)

Natural Gas (NG)

## Power Burner Operational Safety



**WARNING:** During use, and for some time afterwards, the Power Burner will become and stay hot enough to cause serious burns. Do not leave children or pets unattended within the vicinity of the Power Burner until it is no longer in use and has cooled completely. Never allow children to sit, stand, or play on or around the Power Burner.

- Never allow children to operate the Power Burner.
- Never lean over cooking surface while lighting Power Burner.
- Never place objects or utensils on top of Power Burner lid.
- Use barbecue tools with insulated handles and dry, good quality insulated oven mitts when operating the Power Burner. Wet or damp mitts/gloves/pot holders may cause steam burns.
- Allow Power Burner to cool completely prior to transporting or covering your Power Burner for storage.
- Do not place Power Burner under or on top of any surface that will burn.
- Do not allow obstructions or restriction of the flow of combustion and ventilation air around the Power Burner housing.
- Do not build the Power Burner into any combustible structure that is closer than 21 inches from the sides and back.
- Keep the vent openings of the cylinder enclosure, if applicable, free and clear from debris. Clean your Power Burner only with the recommended cleaning agents.
- Keep the fuel supply hose away from any heated surfaces.
- Keep the area encompassing your Power Burner free and clear from any combustible materials, gasoline, and other flammable vapours and liquids.
- Do not operate this Power Burner in temperatures below 0°F (-17°C).

### Gas Conversion Kits:

Gas valves are preset at the Bull factory to operate on either LP gas or Natural Gas. If you wish to convert to a different gas type aside from LP or Natural Gas, be sure to contact your grill dealer, licensed plumber, or authorized service center for further details. Conversion kits will only be sold to professionals to perform conversion service. Failure to properly convert a unit can cause severe injury to yourself and/or others, irreparable damage to your grill and void your warranty.



**INSECT ALERT:** *Spiders and small insects occasionally spin webs or make nests inside the burners during warehousing, transit, and/or after long periods of non-use. These webs or nests can create a hazardous situation where gas flow is redirected and cause a fire type known as "FLASH BACK". This type of fire can cause serious damage to your Power Burner and create an unsafe operating condition. Frequent inspections and care are recommended and detailed further on page 14.*



## Liquid Propane (LP) Safety Guidelines

### ⚠ DANGER:

- Do not store a spare LP gas cylinder under or near this appliance.
- Never fill the cylinder beyond 80% full.
- If the information above is not followed exactly, a fire causing death or serious injury could occur.

### To avoid risk of fire or explosion, please take these safety precautions:

- Never connect an unregulated LP gas cylinder to the Power Burner.
- Do not subject LP gas cylinder to excessive heat.
- The LP gas cylinder must be constructed and marked in accordance with the *Specifications for LP gas Cylinders* of the U.S. Department of Transportation (DOT), or the standard for Cylinders, Spheres and Tubes for the Transportation of Dangerous Goods CAN/ CAS-B339.
- The LP gas cylinder must be provided with a listed overfilling prevention device.
- The LP gas cylinder must be provided with a cylinder connection device compatible with the connection for outdoor cooking appliances.
- Never use an LP gas cylinder that is visibly damaged, dented, or rusty.
- The LP gas cylinder must include a collar to protect the cylinder valve from damage.
- Ensure the LP gas cylinder has appropriate vapor withdrawal.
- Avoid unnecessary twisting of the hose.
- Prior to each use, visually inspect the LP hose for cuts, cracks, excessive wear or damage.
- The supplied pressure regulator and hose assembly (Bull part# 16508) must be used. Replacement pressure regulator and hose assemblies must be the type specified by Bull Outdoor Products.

### When the appliance is not in use:

- The gas shall be turned off at the supply cylinder.
- The Power Burner may be stored indoors if and only if the cylinder is disconnected and removed from the Power Burner.
- The LP cylinders shall be stored outdoors out of reach of children and shall not be stored in a building, garage, or any other enclosed area.

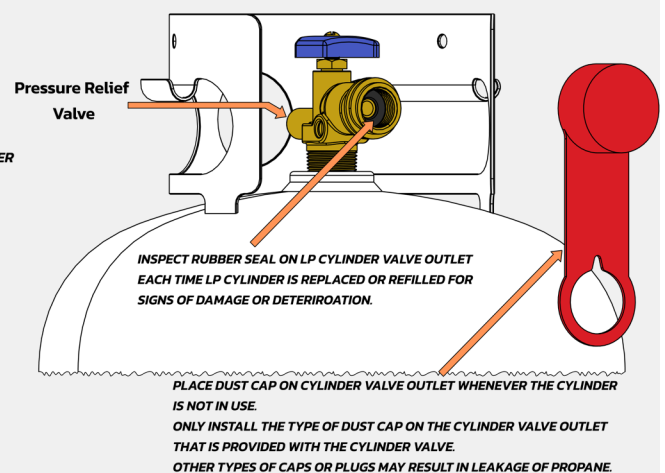
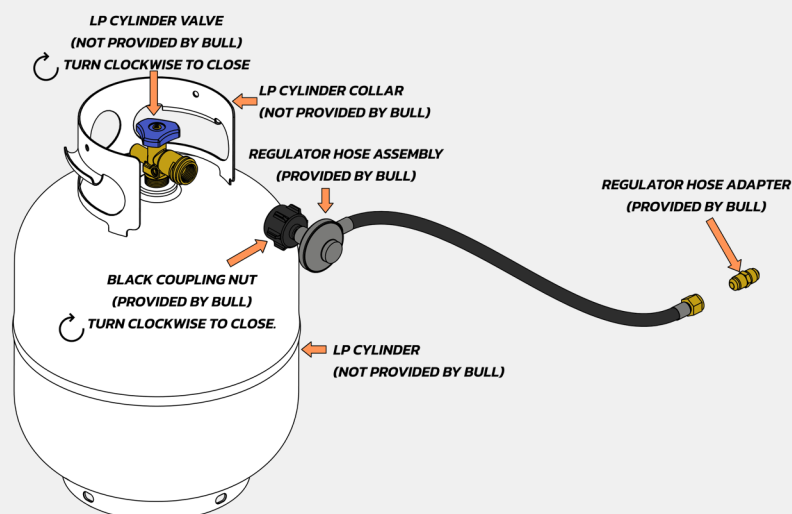

## Liquid Propane (LP) Gas Requirements

Your propane gas Power Burner (SKU# 96000) is designed to operate on propane gas only. Each Power Burner is shipped with an LP regulator hose assembly.

### Connection to the Power

**Burner:** The LP regulator hose assembly comes pre-assembled to the Power Burner manifold

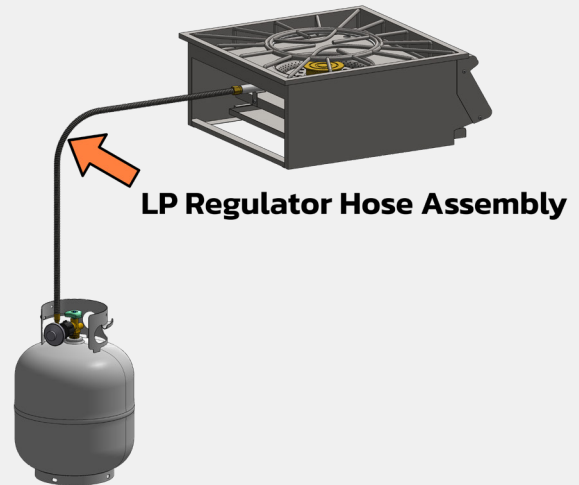

**Cylinder Size:** This Power Burner was designed for use with a standard 20lb (5 gallon) LP gas tank with a Type 1 connection.

**Inlet Pressure:** The provided LP regulator hose assembly maintains an 11" W.C. pressure at the inlet.

**Cylinder Retention:** Integral retention of the LP gas cylinder is required to limit movement of the cylinder. Bull offers many options to satisfy this requirement.

- For built-in applications, SKU# 16674 can be utilized and is shown below.
- Never mount the cylinder in an orientation such that the pressure relief valve is pointed towards the normal operating position of the user.

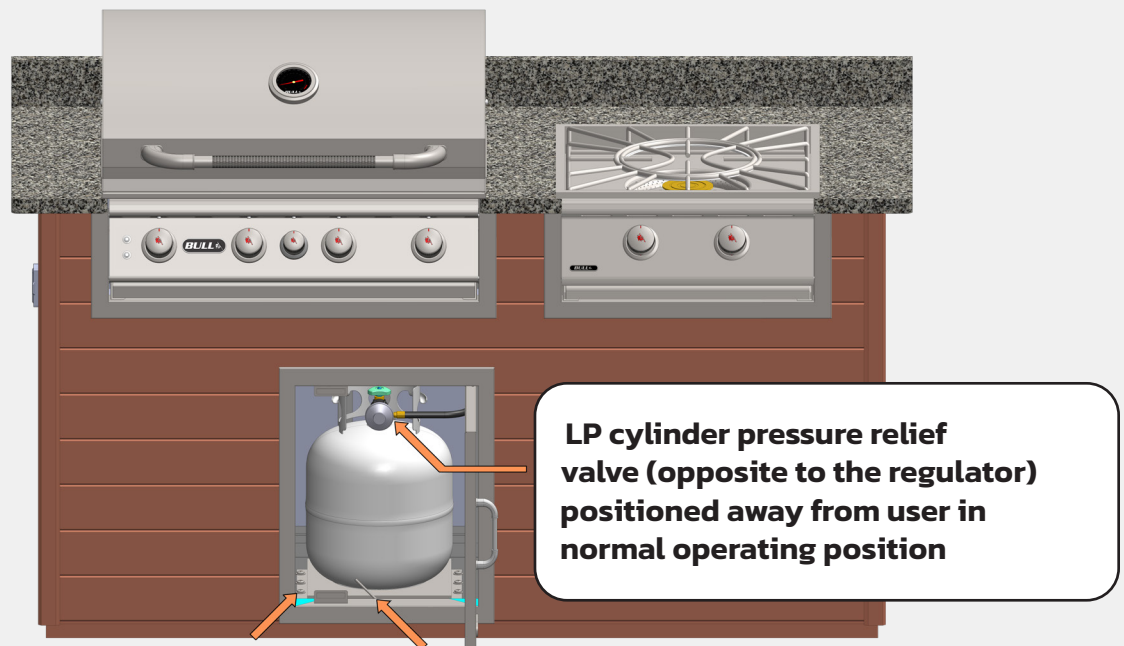

Bull 16674 LP gas cylinder retention system secured to enclosure with:

- 8x Screws
- 8x Washers
- 8x Locknuts

Bull 16674 LP gas cylinder retention bolt.

To secure cylinder:

- Turn clockwise

To remove cylinder:

- Turn counterclockwise

## Natural Gas (NG) Requirements

Your natural gas Power Burner (SKU# 96001) is designed to operate on natural gas only. Each Power Burner is shipped with an NG regulator fastened to the interior side panel of the Power Burner.

**Connection to the Power Burner:** The NG regulator is shipped pre-assembled with one 3/8 NPT to 3/8" Flare\* adapter.

- The provided stainless steel flex hose connects the Power Burner to the outlet of the regulator.
- An additional stainless flex hose with a 3/8" Female Flare\* connection (not provided by Bull) is required to be connected to the regulator and adapter.
- This installer-supplied hose must be connected to an installer-supplied safety shut-off valve located and installed per local codes, or if in areas bereft of local codes, in accordance with ANSI Z223.1/NFPA 54 or CSA B149.1.
- All installer-supplied components for connecting the Power Burner to a fixed fuel piping system such as rigid pipe, semi-rigid tubing, and/or connectors must comply with ANSI Z21.75 • CSA 6.27.
- Do not use Teflon® tape or pipe sealant on any flare ends. Doing so will not allow for a leak-free seal.
- Only use pipe sealing compound or pipe thread tape of the type resistant to the action of natural gas to at least the first three threads of all male pipe threads when making the connection.

\*3/8" refers to the tube outside diameter, *not* thread size.

**Inlet Pressure:** The provided NG regulator maintains an 4" W.C. pressure at the outlet.

**Pressure Testing:** When pressure testing is performed:

- This Power Burner, along with its individual shut-off valve, must be disconnected from the gas supply piping during any pressure testing of that system at test pressures in excess of 1/2 psi (3.5 kPa)
- This Power Burner must be isolated from the gas supply piping system by closing its individual shut-off valve during any pressure testing of the gas supply piping system at test pressures equal to or less than 1/2 psi (3.5 kPa).

**Installer-supplied shut-off valve  
and  
Installer-supplied stainless steel flex hose  
(Not Provided by Bull)**

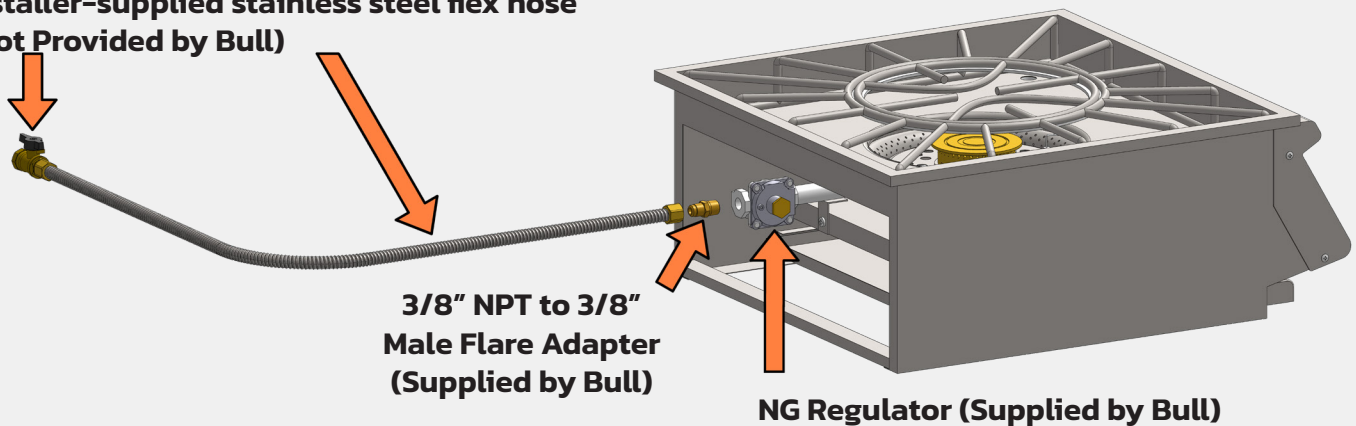

## Checking for Gas Leaks

### When should I test for leaks?

A comprehensive leak test should be performed:

- After initial installation of the Power Burner is complete, and before first using the Power Burner.
- Periodically before (and throughout) the start of a new grilling season.
- For LP model Power Burners, check each time an LP gas cylinder is connected to the Power Burner.
- If you smell gas... however, recall the warning below! Turn off the gas to the Power Burner, and ensure the odor does not linger before continuing with the leak test.

### **⚠ DANGER**

#### **If you smell gas:**

- **Shut off gas to the appliance.**
- **Extinguish any open flame.**
- **Open Lid.**
- **If odor continues, keep away from the appliance and immediately call your gas supplier or your fire department.**

### How do I perform a leak test?

- It is recommended to use a leak detection compound conforming to MIL-L-25567D. Alternatively, mix a 1:1 solution of liquid detergent and water into a spray bottle.
  - ◇ *Never use an open flame to test for leaks.*
- Ensure all heat control valves are turned off and then turn on the gas supply.
- Apply the leak detection solution to all components of the gas delivery system, which consists of valves, connectors, piping, and hoses, at every point from the gas supply to the burners.
- Visual indicators of a failed test are any blowing bubbles present in the leak detection solution.
- Olfactory indicators of a failed test are any faint sulfurous smells present similar to that of rotten eggs.

**IMPORTANT:** Rectify any leaks immediately and do not use the Power Burner until all connections have been checked and are leak-free.

### LP Leak Test Detail

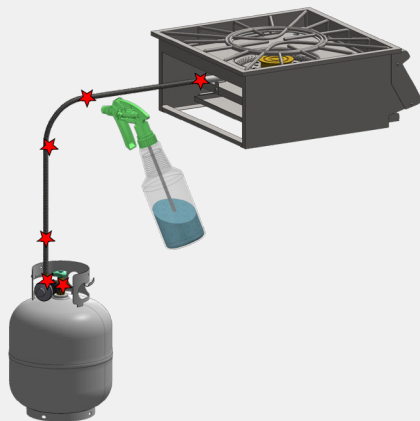

### NG Leak Test Detail

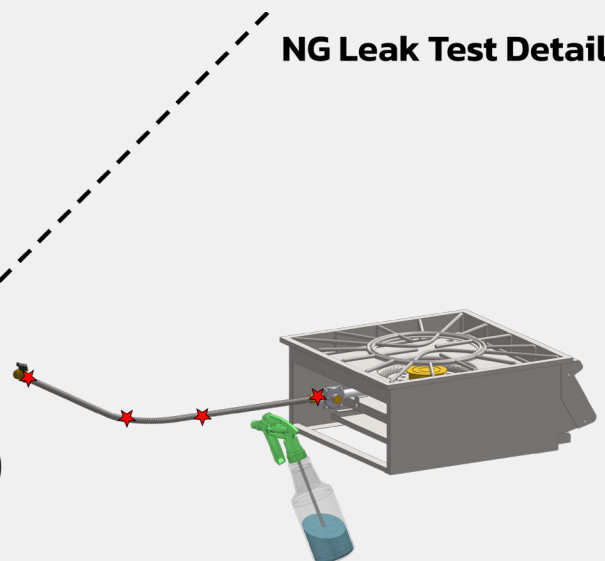

Bubbles Indicate Leak

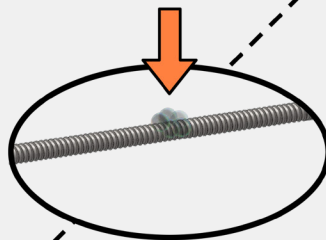

**★ Apply Solution at locations indicated by this symbol**

## Determining the Location of the Power Burner

This Power Burner is for outdoor use only. An appliance is considered to be outdoors if:

- Installed with shelter no more inclusive than with walls on three sides, but with no overhead cover; all openings must be permanently open; sliding doors, garage doors, windows, or screened openings are not considered as permanent openings. **OR**
- Installed with shelter no more inclusive than within a partial enclosure that includes an overhead cover and no more than two sidewalls. The sidewalls may be parallel, as in a breezeway, or at right angles to each other; all openings must be permanently open; sliding doors, garage doors, windows, or screened openings are not considered as permanent openings. **OR**
- Installed with shelter no more inclusive than within a partial enclosure that includes an overhead cover and three sidewalls, as long as 30% or more of the horizontal periphery of the enclosure is permanently open. All openings must be permanently open; sliding doors, garage doors, windows, or screened openings are not considered as permanent openings.
- This appliance is not intended to be installed in or on a boat or recreational vehicle.

### Clearance to Combustible Materials

- Maintain a distance of 21" from both sides and back of the Power Burner to any combustible materials.
- If installed under overhead combustible construction, a suitable UL 710 approved heavy duty vent hood must be installed in conjunction with the Power Burner.
- The vent hood must be placed in operation while the Power Burner is being used.

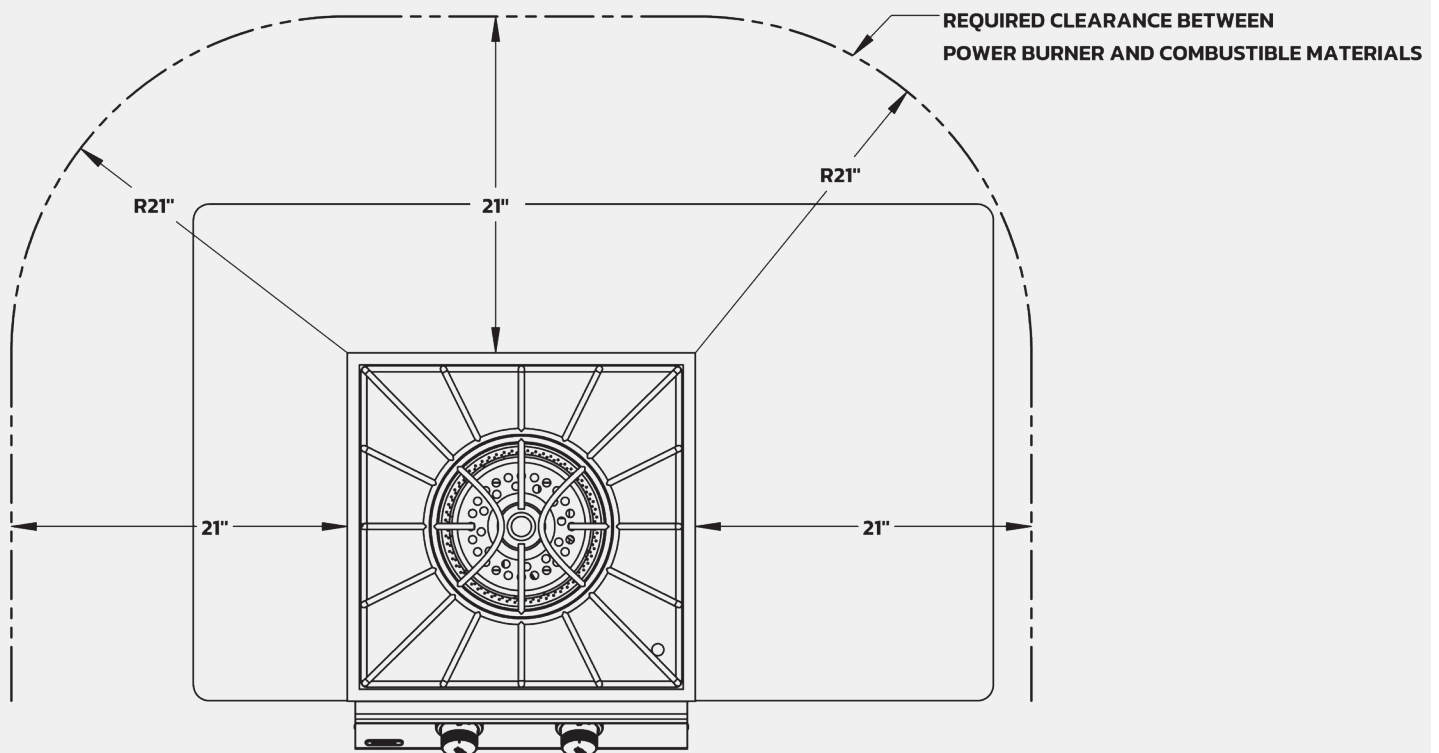

## Power Burner Enclosure Requirements

When installing the Power Burner for built-in applications, do not use any combustible materials for the Power Burner enclosure construction.

### LP Cylinder Enclosure Required Provisions:

For LP Power Burner models (SKU# 96000), additional considerations must be made when constructing the enclosure:

- The Power Burner enclosure must contain a separate, isolated enclosure for storage of the LP gas cylinder. The storage for the LP gas cylinder must be designed such that only the LP gas cylinder being used can fit in this compartment. It should not be physically possible to store a spare LP gas cylinder vertically, horizontally, or in any orientation within the enclosure when the LP gas cylinder currently in use is installed and properly retained.
- This separate enclosure for the LP gas cylinder shall isolate the cylinder from the burner compartment in order to provide:
  - ◇ Shielding from radiation
  - ◇ A flame barrier
  - ◇ Protection from foreign material, such as hot drippings
- There must be a minimum of 2 inches between the floor of the LP gas cylinder enclosure and the ground.
- The LP gas cylinder must be easily connected and disconnected, and connections shall be able to be tested outside the cylinder enclosure.
- Connections which could be disturbed when installing the cylinder must be accessible for leak testing inside of the enclosure.
- The LP gas cylinder enclosure must include some means of retention as detailed on page 6.

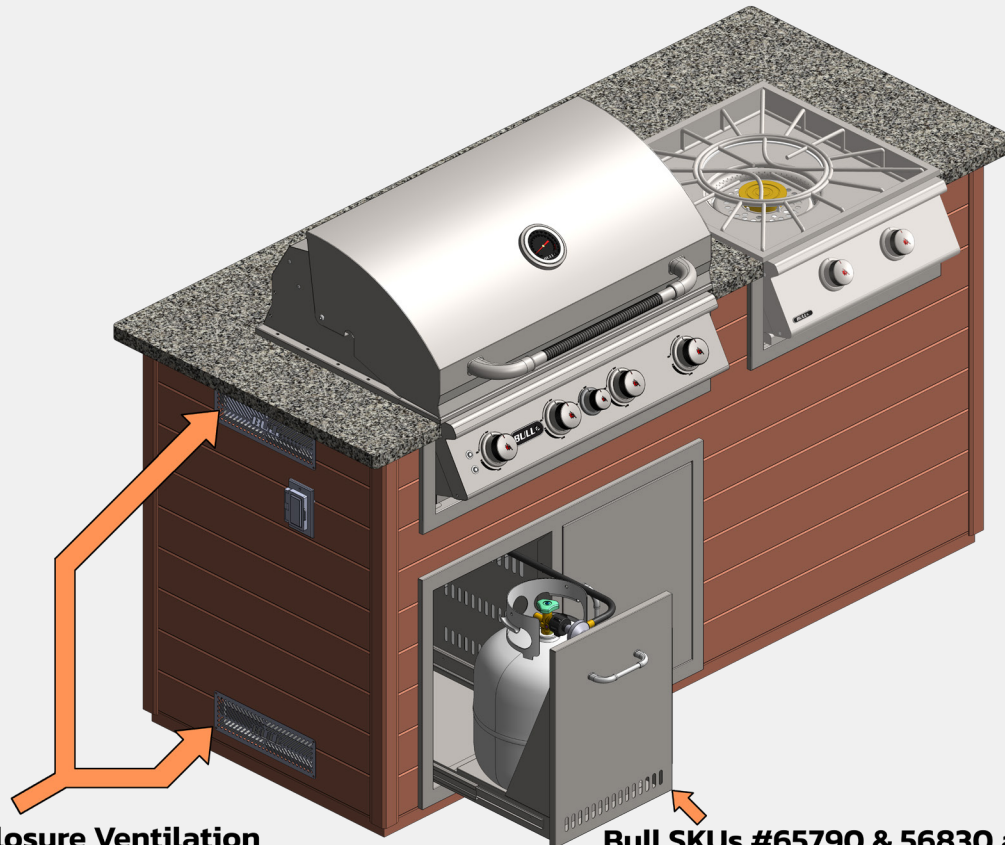

**Required Enclosure Ventilation**

**Bull SKUs #65790 & 56830 are available to help satisfy requirements above**

## LP Cylinder Enclosure Ventilation:

**⚠ WARNING:** Failure to adequately ventilate your outdoor kitchen could result in an explosion or fire.

The enclosure for the LP gas cylinder shall be properly ventilated. The proper ventilation of the enclosure shall be accomplished by one of the following options:

1. One side of the enclosure shall be completely open.
2. For a cylinder enclosure having four sides, a top, and a bottom, and intended for installation in a built-in enclosure:
  - ◇ At least one ventilation opening shall be provided on the exposed exterior side of the enclosure located within 5 in (127mm) of the top of the enclosure and unobstructed. The opening(s) shall have a total free area of not less than 1 in<sup>2</sup>/lb (14.2 cm<sup>2</sup>/kg) of stored fuel capacity (20in<sup>2</sup> for a 20lb LP gas cylinder).
  - ◇ At least one ventilation opening shall be provided on the exposed, exterior side of the enclosure 1 in (25.4 mm) or less from the floor level and shall have a total free area of not less than 1/2 in<sup>2</sup>/lb (7.1 cm<sup>2</sup>/kg) of stored fuel capacity (10in<sup>2</sup> for a 20lb LP gas cylinder). The upper edge shall be no more than 5 in (127mm) above the floor level.
  - ◇ Every opening shall have a minimum dimension so as to permit the entrance of a 3/16 in (4.8mm) rod.

**IMPORTANT:** The requirements listed above are the MINIMUM. Bull recommends having ventilation openings on all exposed exterior sides at both top and bottom. The ventilation openings should be sized and located as outlined above.

## Power Burner Counter top Cutout Dimensions:

Dimensions shown below are in inches and for use with non-combustible constructions only.

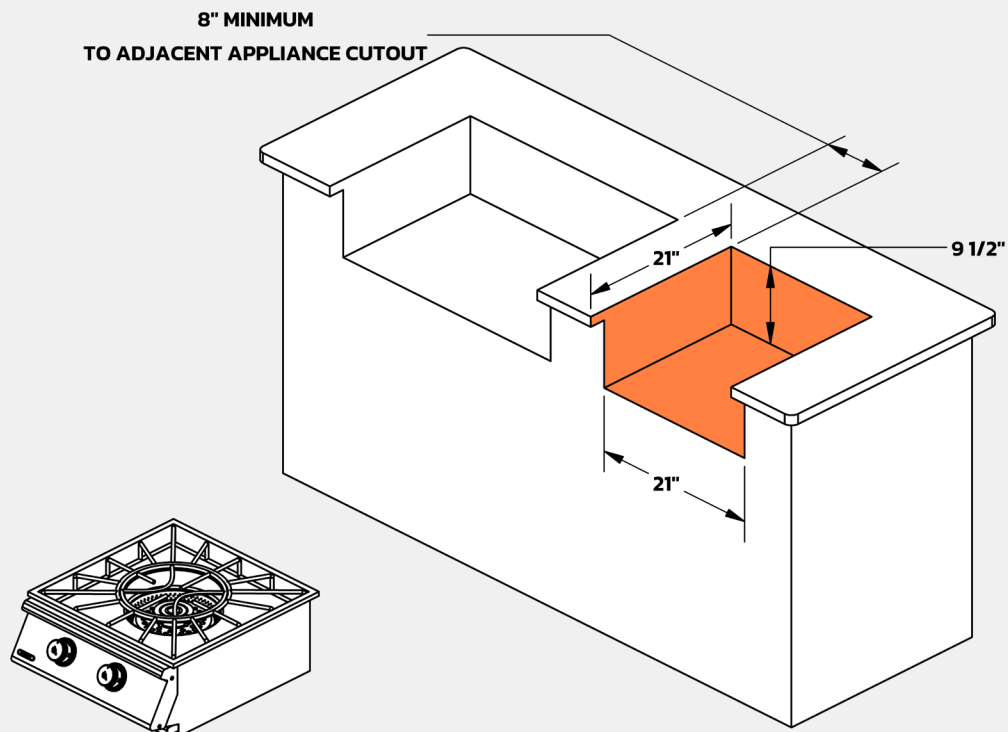

## Lighting the Power Burner

Prior to lighting your Power Burner, ensure you have become familiar with the safety guidelines and instructions presented in this manual thus far.

Never attempt to light your Power Burner if you smell any odor resembling gas. Perform a leak test as prescribed in this document before proceeding.

### Power Burner Standard Lighting Procedure:

1. Begin by confirming that all burner control valves are set to the "OFF" position.
2. Turn the supply gas on.
3. Push in the control knob of the burner you intend to light. Slowly, for roughly 3-4 seconds, rotate the knob counterclockwise by approximately a 1/4 turn. An audible \*CLICK\* should be heard. By the time the click is heard, the burner orifice should have provided enough gas to ignite and a visible flame should be present. **If the burner does not ignite, immediately return the control knob to the "OFF" position;** wait five minutes for any gas to disperse and repeat this process.
4. Adjust the control knob(s) to the desired cooking temperature.



### Power Burner Manual Lighting Procedure:

If the ignitors fail to produce a spark at the electrode tip, the burners can be manually ignited using a long-necked lighter.

1. Begin by confirming that all burner control valves are set to the "OFF" position.
2. Turn the supply gas on.
3. Use long-necked lighter, placing the flame near to the burner ports.
4. Push in the control knob of the burner you intend to light. Slowly, for roughly 3-4 seconds, rotate the knob counterclockwise by approximately 1/4 turn. An audible \*CLICK\* should be heard. By the time the click is heard, the burner orifice should have provided enough gas to ignite. If the burner does not ignite, immediately return the control knob to the "OFF" position; wait five minutes for any gas to disperse and repeat this process.
5. Adjust the control knob(s) to the desired cooking temperature.

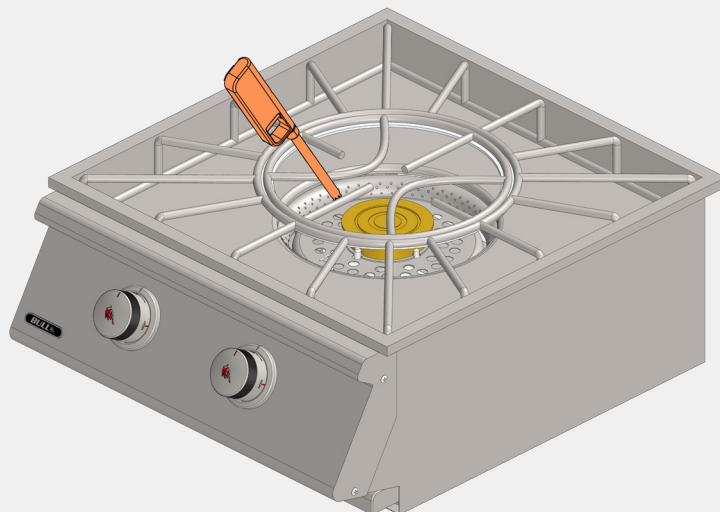

## Burner Flames

Each burner on your Power Burner is preset by the factory for best performance. However, many factors such as variations in your gas supply, or dirty/clogged air shutters and/or orifices may cause your burners to not operate as intended.

- Flames should be blue and stable. Any yellow flame (excluding at the very tips) indicates insufficient air supply.
- Flames should be quiet. A noisy, lifting flame indicates excessive air supply.
- Flame heights should be approximately:
  - ◇ 1/4" on "LOW"
  - ◇ 1-3/4" on "HIGH"

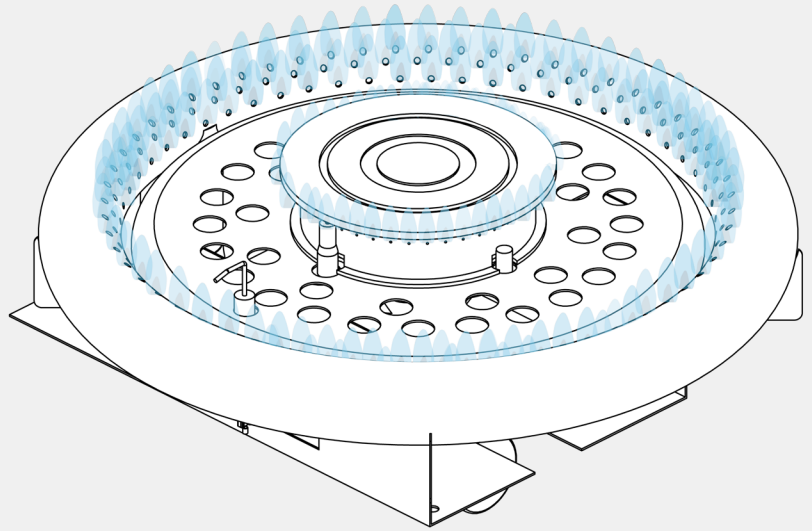

### Air Shutter Adjustment:

With the grease tray removed, the air shutters are easily adjustable.

Simply loosen the single screw present on the outer burner which secures the shutter to the burner and rotate the shutter as needed to correct the issues mentioned above.

- If too much air is being supplied (noisy, lifting flame), rotate the shutter to restrict the amount of air entering the burner.
- If too little air is being supplied (yellow/orange flame), rotate the shutter to allow for more air to enter the burner.
- Once adjustments have been made, tighten the screw back to prevent the shutter from shifting during operation.

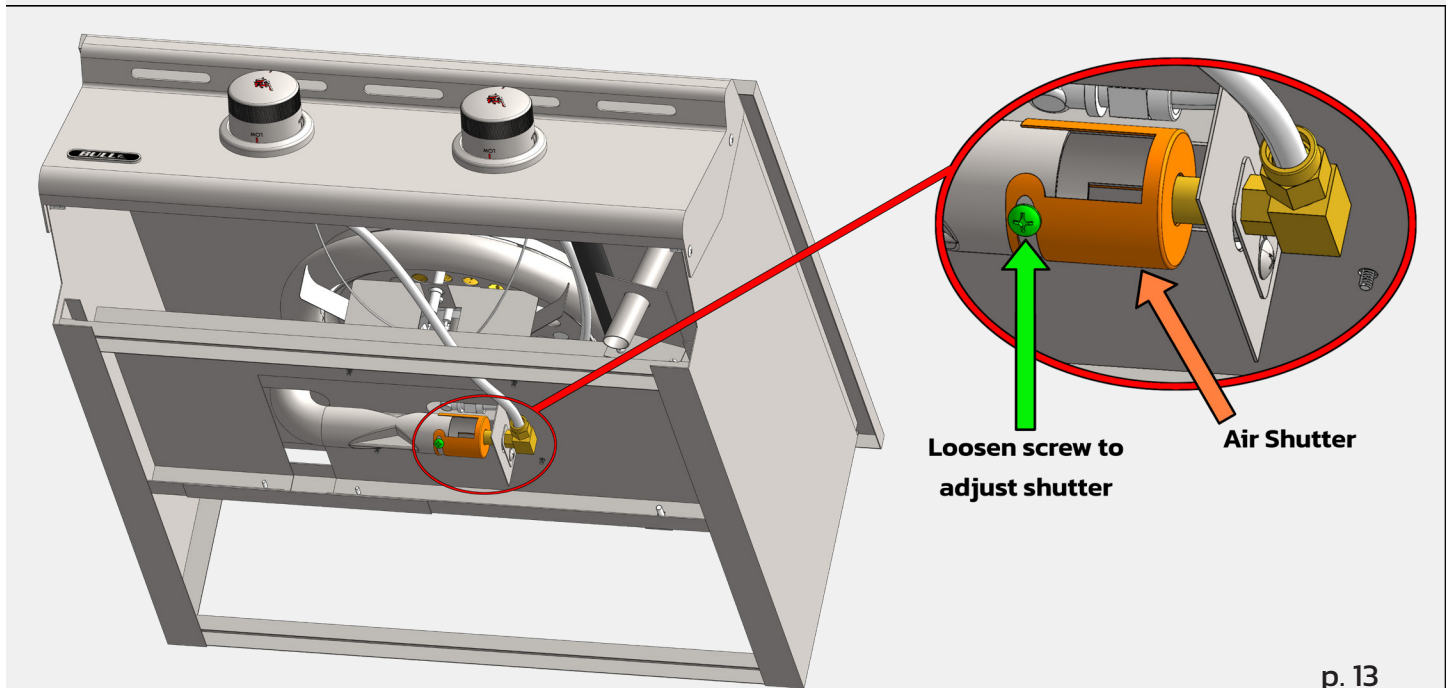

## Burner Maintenance

Proper maintenance of your Power Burner burners will not only keep your burners in pristine shape, but also reduces the risk of flashbacks as described on page 4.

At least once a month, or when your Power Burner has not been used for a prolonged period of time, it is imperative to inspect and clean your burners. To properly inspect and clean your burners, they should first be removed from the Power Burner as instructed below.

Before proceeding, always follow these instructions:

1. Do not attempt to remove burners during or immediately after use.
2. Allow the Power Burner to cool completely before touching.
3. Always ensure the supply gas is turned off.
4. All the burner control knobs should be set to the "OFF" position.
5. Remove the grease tray, lid, and both cooking grates.
6. Disconnect the flexible fuel line from the manifold. This line is behind the right side of the control panel and can be accessed from underneath the Power Burner.

### Center Burner Removal and Cleaning:

The center burner on the Power Burner simply rests in the burner base, and no tools are required for removal. Lift the two-piece burner out.

With the burner removed:

- Begin by inspecting the burner base and all outlet ports, and verify they are damage free and clear of debris.
- Check for any signs of corrosion, cracks, or holes. If any such damage is identified, order and install a new burner before returning to service.
- Clean the burner(s) as detailed to the below.
- Once inspected and cleaned, re-install the burner in reverse order of disassembly.

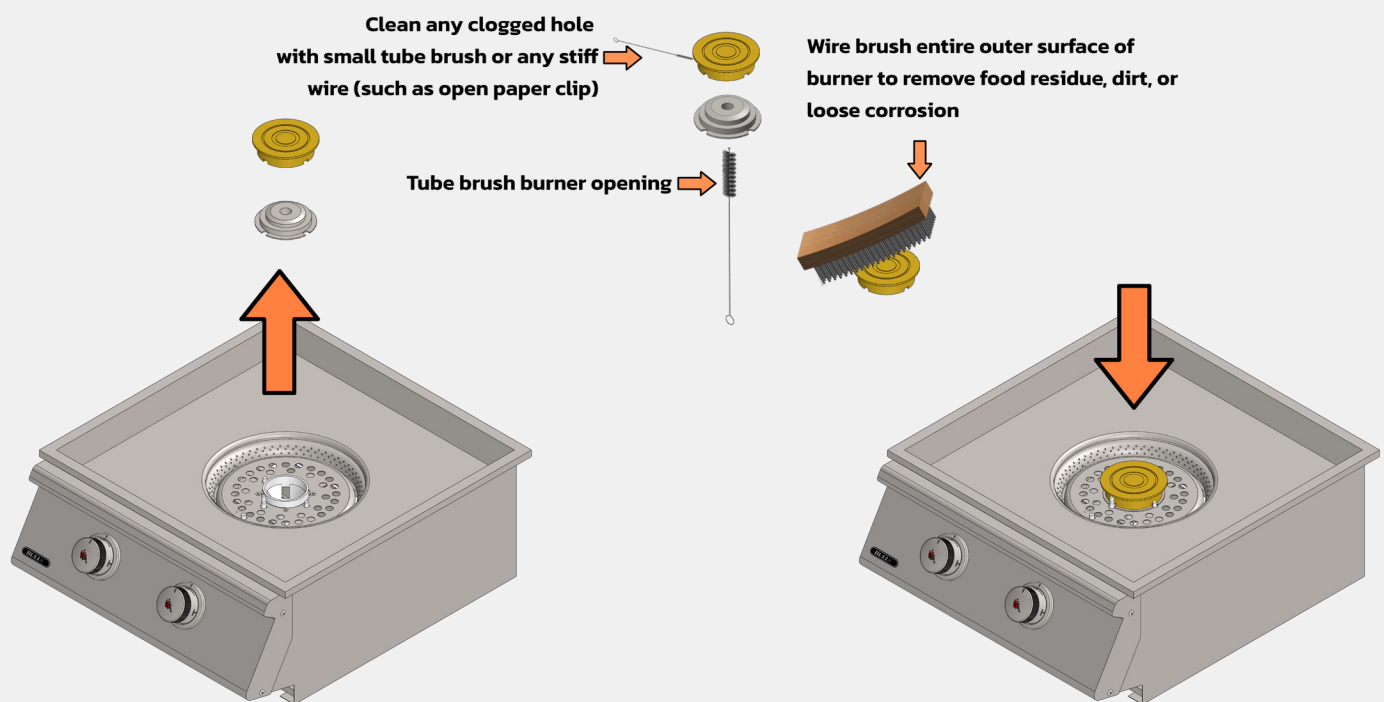

## Outer Burner Removal and Cleaning:

1. Begin by removing the insert bracket by unscrewing the two screws as shown.

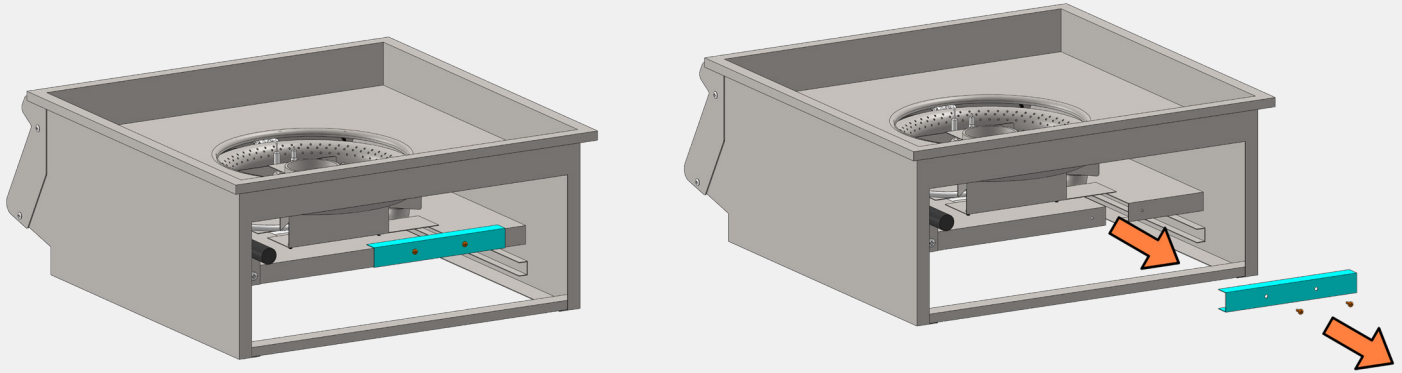

2. Remove the four screws securing the heat shield and carefully remove the heat shield.

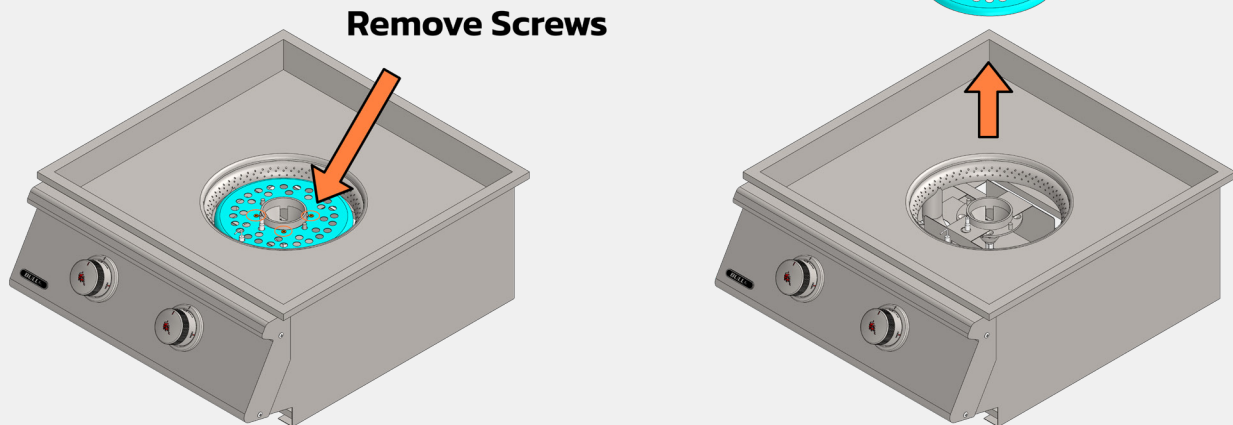

3. Push down on the inner burner to release it from the outer burner bracket. There is a slot at the bottom of the outer burner that will allow for some maneuvering. Rotate the inner burner until the ignitor clears the hole in the outer burner bracket and is free from the outer burner.

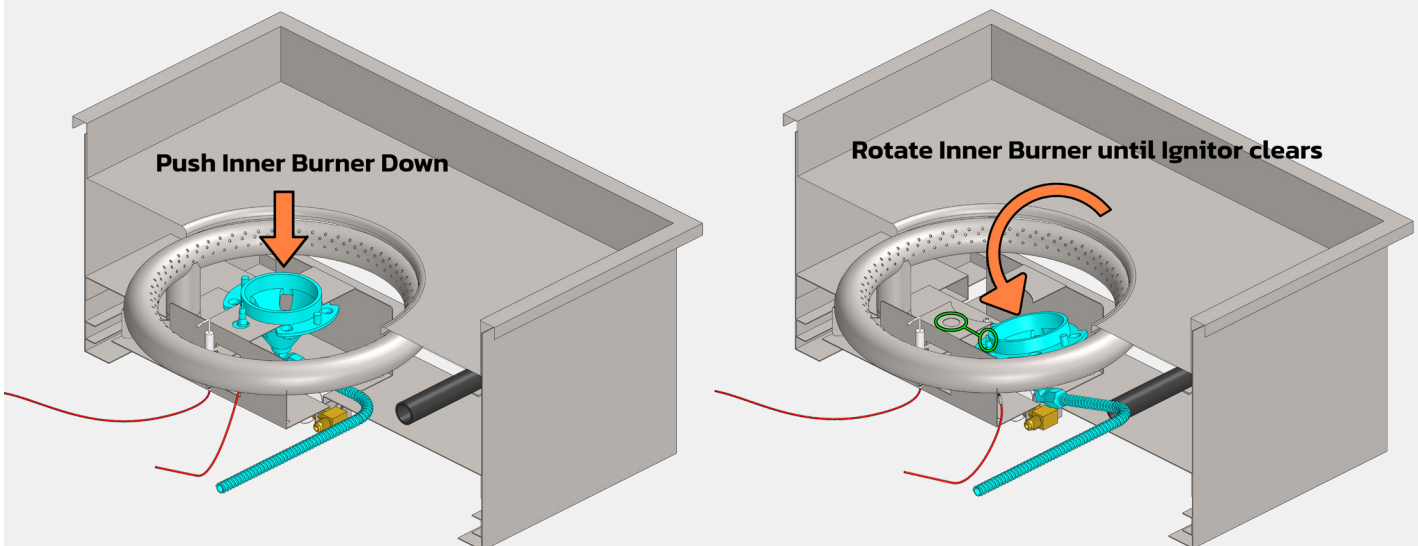

4. With the inner burner freed from the outer burner bracket, disconnect the ignitor cable and flex hose. The inner burner is now free to be lifted up and out of the base.

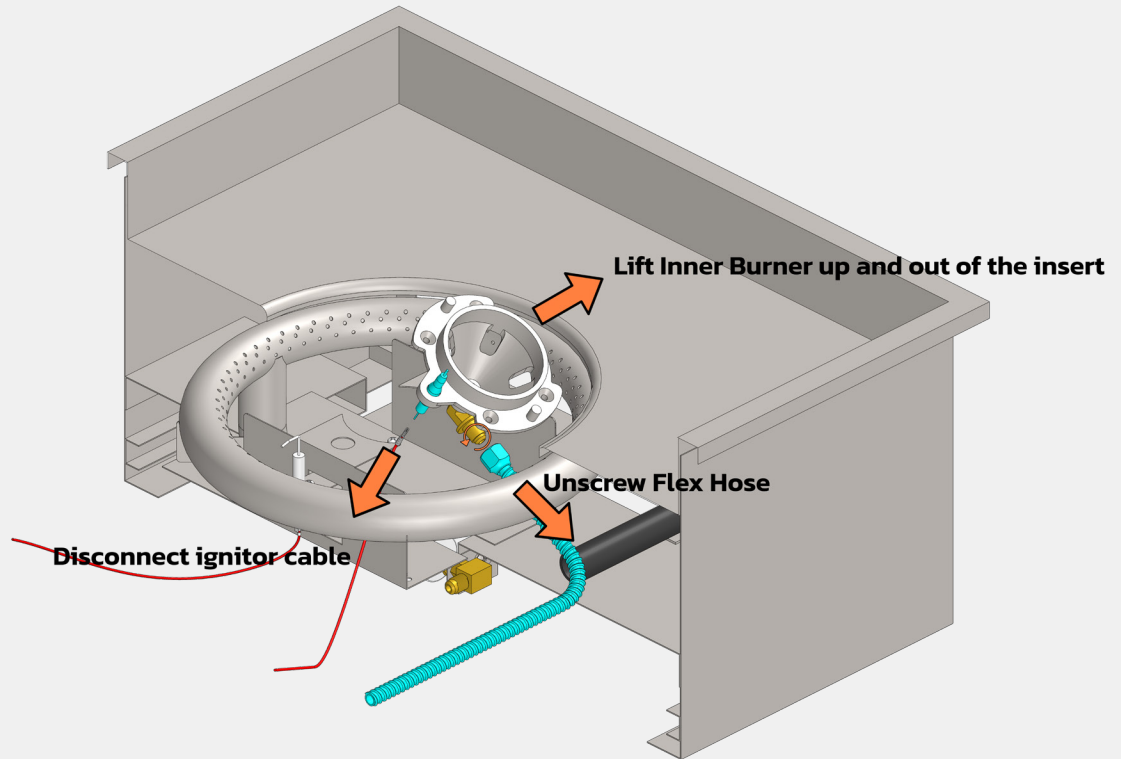

5. Disconnect the ignitor cable on the outer burner

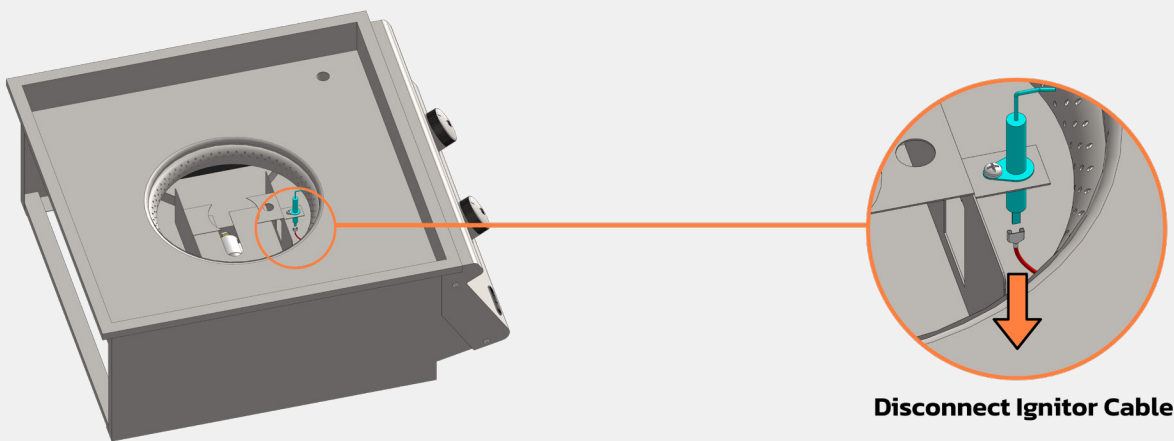

6. Remove the four screws securing the outer burner to the base of the power burner.

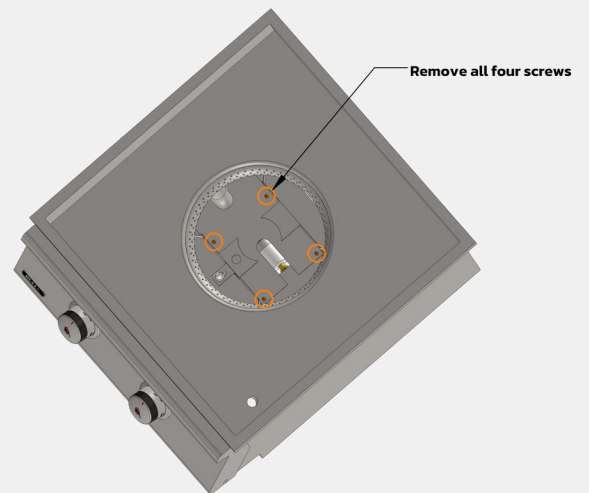

7. Slide the outer burner away from the orifice while also rotating the burner clockwise, carefully routing the burner until it is free from the cutout on the base of the Power Burner.

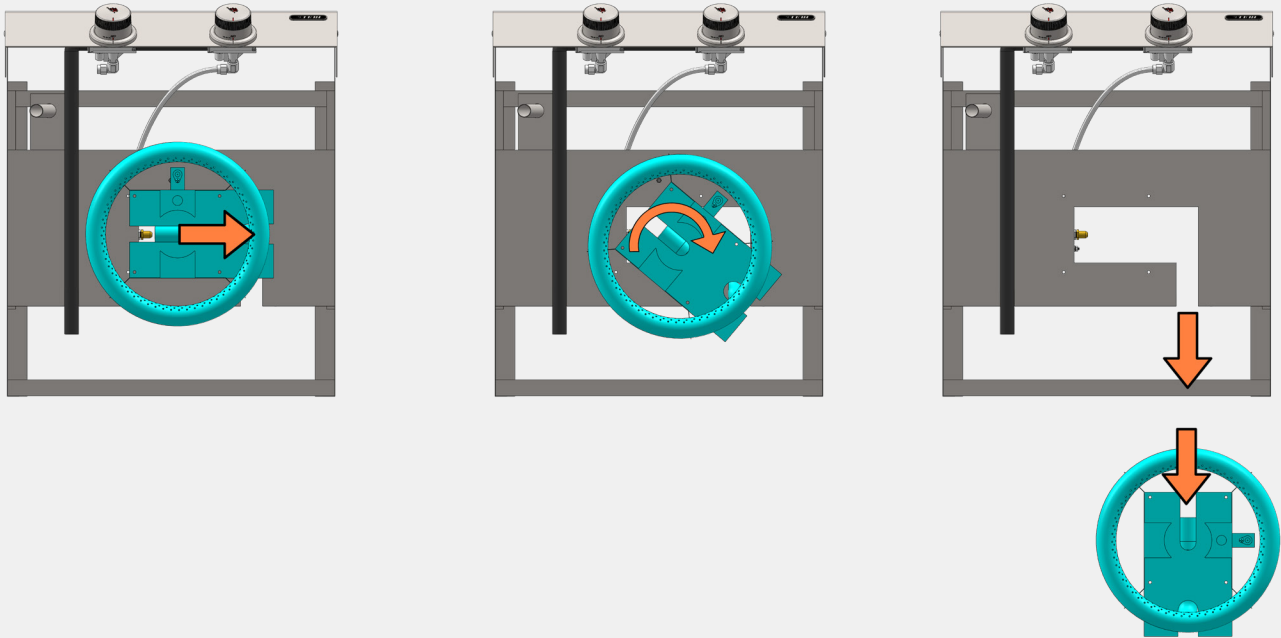

With the burner removed:

- Begin by inspecting the burner base and all outlet ports, and verify they are damage free and clear of debris.
- Check for any signs of corrosion, cracks, or holes. If any such damage is identified, order and install a new burner before returning to service.
- Clean the burner(s) as detailed below.
- Once inspected and cleaned, re-install the burner in reverse order of disassembly.

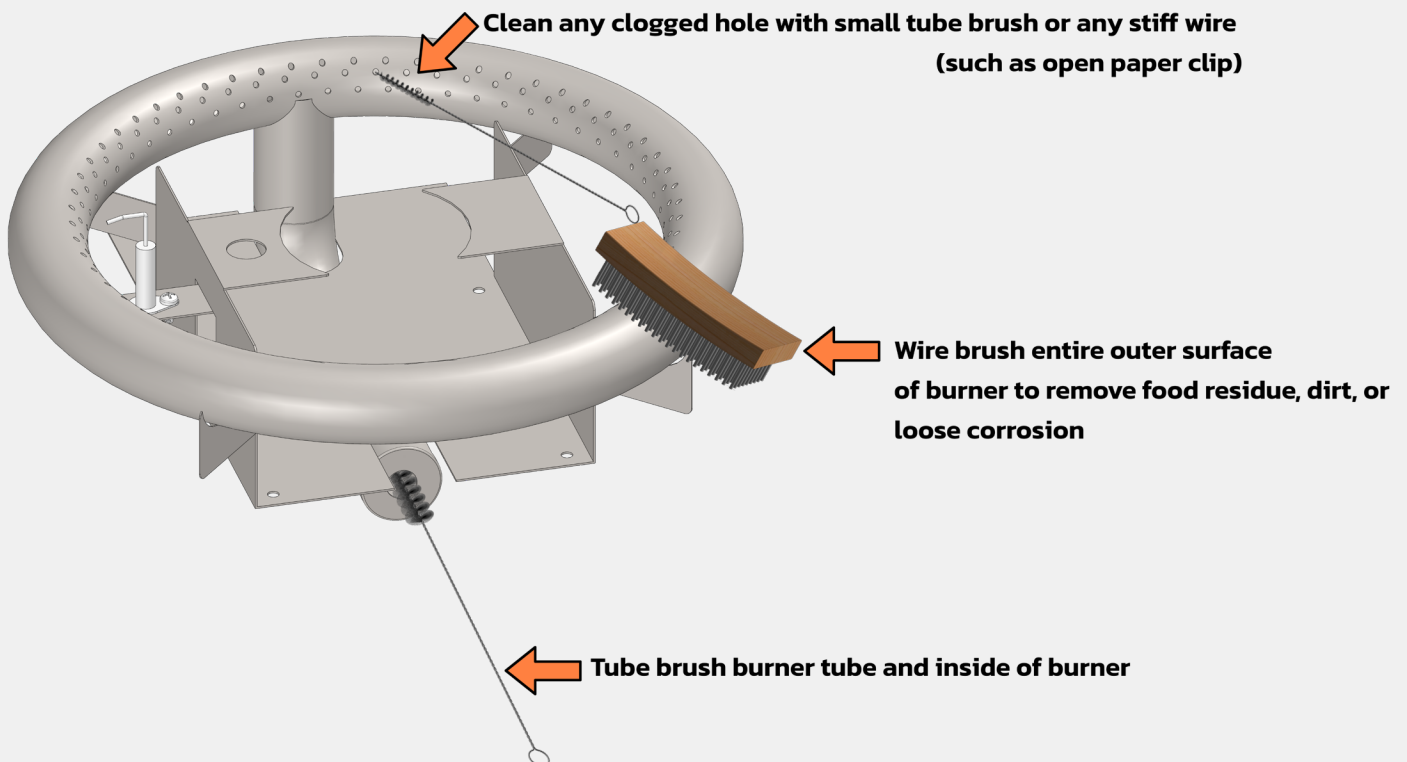

## Burner Installation

When re-installing the outer burner, verify that the burner tube is properly located with respect to the burner valve orifice as shown below.

**WARNING:** If the valve orifices do not fit inside the burner tubes, lighting the burners may cause an explosion and/or fire

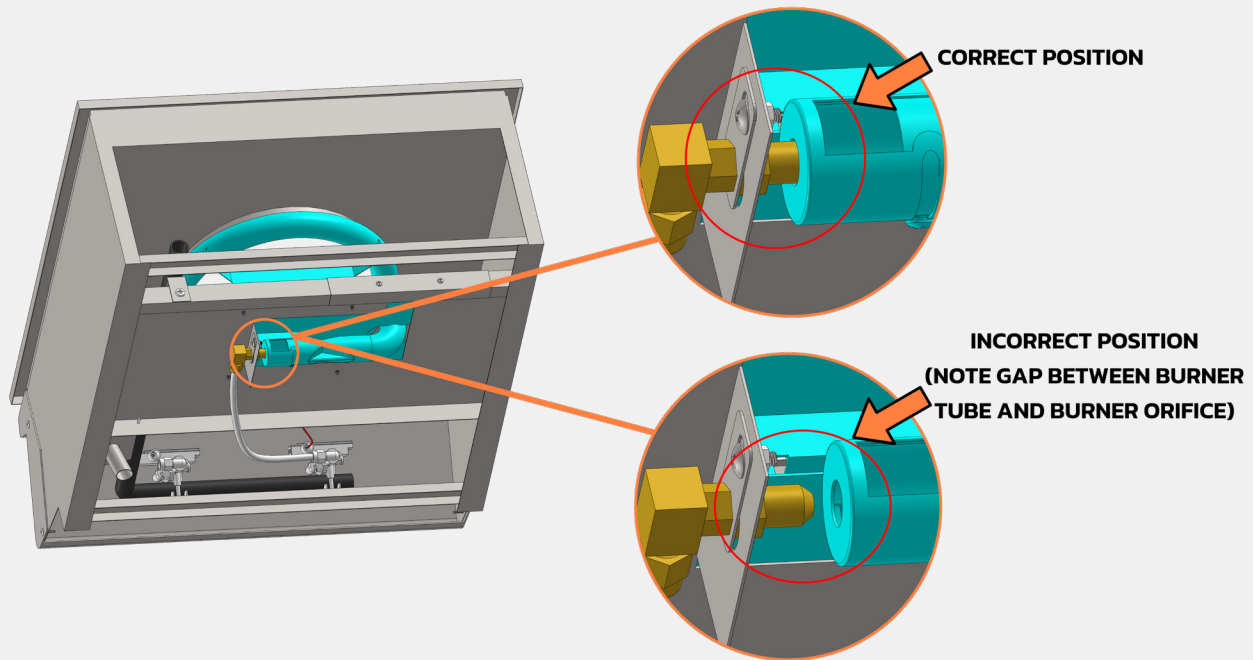

### Ignition System Inspection:

After re-installation of the burners is a good time to perform an inspection on your Power Burner's ignitors. This is accomplished with the following procedure:

1. Ensure the supply gas to the Power Burner is turned off.
2. Ensure all control knobs on the Power Burner are set to the "OFF" position.
3. One-by-one, push in each control knob and slowly turn approximately 1/4 turn counterclockwise until an audible \*CLICK\* is heard. Prior to the click, look near the valve's ignitor orifice and be on the lookout for a blue spark at the electrode tip by the ignitor orifice.
4. Once the click is heard, determine if a blue spark was present. If not refer to page 20 for troubleshooting.

**Blue spark should be seen at electrode tips when \*CLICK\* is heard**

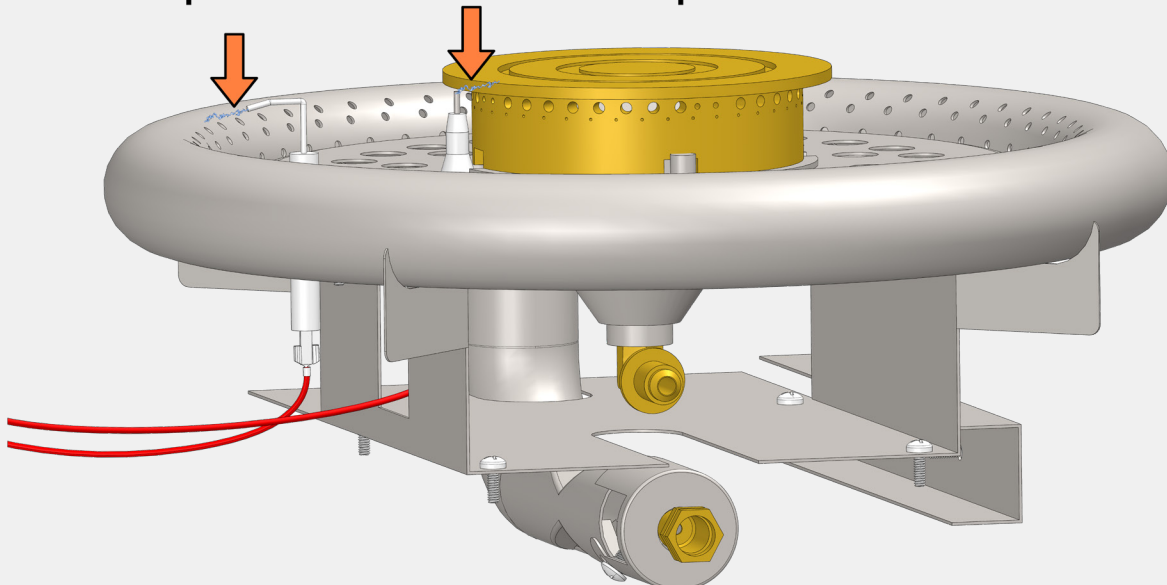

## ***Cleaning the Power Burner***

Your Power Burner's outstanding luster and durability is attributed to Stainless Steel construction. Stainless Steel has an outer layer that relies on a proper cleaning and maintenance routine as the best way to prevent corrosion. Please note, Stainless Steel is not 'rust proof' contrary to widespread belief. Power Burners are at higher risk of corrosion by exposure to chemicals, caustics and fertilizers from swimming pools and outdoor landscaping. Locations with climates with greater heat and humidity will intensify this condition. By following a proper cleaning routine, you will add to the years you enjoy your Bull Power Burner.

### **Cooking Grates:**

After cooking, turn control knobs to "OFF" and let Power Burner cool before attempting to clean your cooking grids. Before first use and periodically it is suggested that you wash the cooking grids in a mild soap and warm water solution. You can use a washcloth or a vegetable brush to clean your cooking grids.

### **Heat Shield:**

Washing the heat shield after every use is not necessary but periodically it is suggested you wash it in a soap and warm water solution. Use a wire brush to remove stubborn cooking residue. Dry the heat shield thoroughly before you reinstall it in the cooking insert.

### **Grease Tray:**

The grease tray should be emptied and wiped down periodically and washed as needed.

### **Power Burner Housing:**

Burning-off the Power Burner after every cookout will keep it ready for instant use. However, periodically the Power Burner should be cleaned thoroughly to ensure optimal performance. Bull recommends doing the following on an annual basis:

1. Shut off gas supply at source and disconnect fuel line from gas valve manifold. Protect fuel line fitting.
2. Remove and clean the cooking grates, heat shield, and burners.
3. Cover the gas valve orifices with a piece of aluminum foil.
4. Brush the inside and bottom of the Power Burner with a stiff wire brush and wash down with a mild soap and warm water solution. Rinse thoroughly and let dry.

**IMPORTANT:** Do not line the bottom of the Power Burner housing with aluminum foil, sand, or any other grease absorbent substance. Grease will not be able to drip down into the grease collector as intended and a grease fire could occur. Bull offers a grease tray liner (SKU# 24268) for easy clean up and maintenance.

## Troubleshooting

If your Power Burner is not functioning properly, use this troubleshooting table below to diagnose and address your issue. If you are unable to remedy your problem, consult your Power Burner dealer or gas appliance service person.

Issue	What to do
Power Burner Fails to Light	<ul style="list-style-type: none"><li>• Turn off gas at supply-end, turn control knobs to the "OFF" position.</li><li>• Check gas supply and all connections.</li><li>• Wait five minutes.</li><li>• Repeat standard lighting procedure on Page 12.</li><li>• If issue still persists, check for potential causes below.</li></ul>
Obstruction in Gas Line	<ul style="list-style-type: none"><li>• Disconnect fuel line from Power Burner.</li><li>• Open gas supply briefly to dislodge any obstructions from the fuel line.</li><li>• Close off the supply line at the source and reconnect the supply to the Power Burner.</li></ul>
Misaligned Ignitor	<ul style="list-style-type: none"><li>• Check the position of the electrode tip on each burner valve. The tip of the electrode should be pointing forward toward the burner and free from grease where the spark discharges.</li><li>• The ignition wire should be rigidly connected to the valve ignition and electrode.</li><li>• Replace the ignition wire if broken or cracked.</li><li>• Verify ignitor is working properly by following procedure outlined on Page 18.</li></ul>
Plugged Burner Orifice	<ul style="list-style-type: none"><li>• Remove burners following instructions starting on Page 15.</li><li>• Remove the orifice located on the burner valve.</li><li>• Gently clean with a fine wire to clear any obstruction that may be present.</li><li>• Reinstall burner orifice.</li><li>• Reinstall burners, properly seating over orifice as shown on Page 18.</li><li>• Perform ignitor test (Page 18) to confirm it is working.</li><li>• Replace cooking components and grease collectors before attempting to light the Power Burner.</li></ul>

Issue	What to do
Burner Flame is Yellow	<ul style="list-style-type: none"> <li>• The burner may have seasoning salts, oil film, or other foreign matter causing the discolored flame. Clean the burner with a wire brush and see if problem persists.</li> <li>• Air shutter on gas valve may need adjustment (Page 13). Increase air supplied to valve by opening the shutter.</li> </ul>
Burner Flame is Lifting/Noisy	<ul style="list-style-type: none"> <li>• Air shutter on gas valve may need adjustment (Page 13). Decrease air supplied to valve by closing shutter.</li> </ul>
Flashback	<ul style="list-style-type: none"> <li>• When a fire occurs in or around the burners, immediately turn off the gas supply.</li> <li>• Turn all control knobs to the "OFF" position.</li> <li>• Wait until the Power Burner has cooled completely.</li> <li>• Remove the affected burner(s) following instructions on Page 14.</li> <li>• Clean the burner(s) as shown on Page 14 and 17.</li> </ul>

**IMPORTANT:** During troubleshooting you may find re-ignition necessary. Do not re-light the Power Burner while it is still hot. You must wait at least five minutes to allow accumulated gas to disperse.

## Product Warranty and Registration

Thank you for choosing Bull Outdoor Products. To enable our commitment to your satisfaction, you will need to register your purchase for it to be covered under Bull's warranty policy. Please save your purchase receipt as it is required for warranty claims. Additionally, registering your purchase will allow Bull or your Bull Authorized Dealer to utilize the encoded information for the purpose of ordering replacement parts or additional accessories to ensure your purchase remains in optimal working condition. To validate your warranty, we offer two options as shown below:

### Option 1: Online Registration

 Registration can be completed on the Bull Customer Service Portal

 Scan the QR code, or visit: <https://api.bullbbq.com/c/>

### Option 2: Mail-in Registration

Complete the Product Warranty Registration Card located in the shipping box. A reference of the card is shown to the right.

Mail the completed card to:

**BULL OUTDOOR PRODUCTS, INC.**  
**15 East Ave, Athens, TN**  
**Attn: Warranty Service Center**



### Unpacking the Power Burner:

After opening the box, carefully inspect the contents for any damage. Contact our service center or local dealer for replacement of any damaged/missing parts. If damaged, do not attempt to install.

### Ordering Replacement Parts:

Please refer to your owner's manual parts list and illustration(s) to identify what you need. Have your serial number ready. Replacement parts can be purchased via two options.

### Option 1: Online

 Scan the QR code, or visit:  
<https://bullbbq.com/buy-parts>

### Option 2: Phone

We have two authorized parts distributors ready to assist.

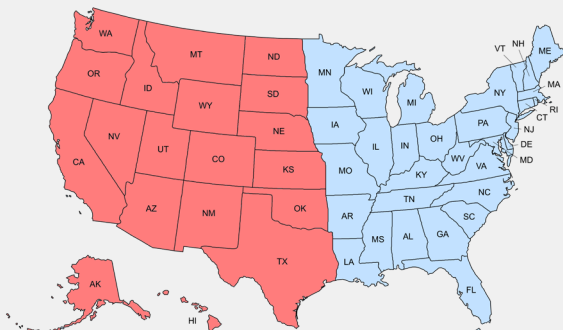

**Western Region**  
**(800) 258-6810**

**Eastern Region**  
**(800) 229-3056**

### Serial Number Locations:

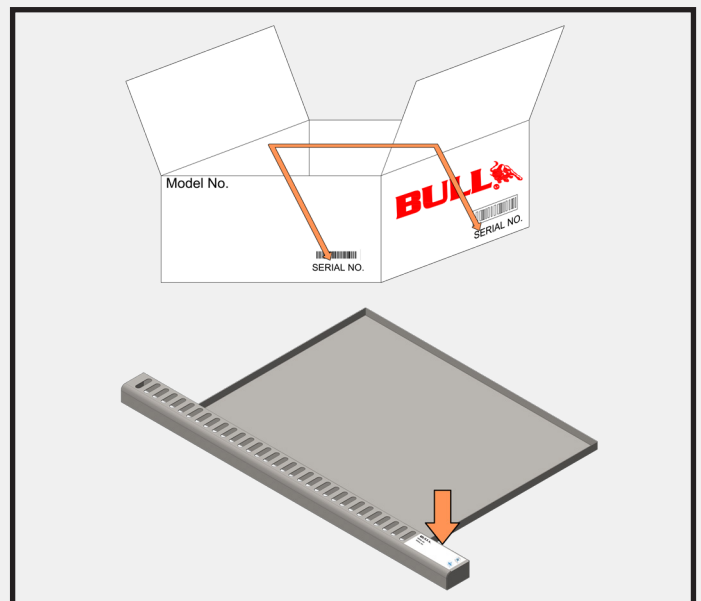

# Replacement Parts List

ITEM NUMBER	BULL SKU#	DESCRIPTION	QTY	WARRANTY PERIOD (YEARS)
1	96100	INSERT ASSEMBLY	1	LIFETIME
2	96101	LID	1	1
3	96102	GREASE TRAY	1	1
4	96120	GREASE CATCH	1	1
5	96103	GREASE TRAY	1	1
6	16613	BURNER CONTROL KNOB	2	1
7	16629	BEZEL FOR CONTROL KNOB	2	1
8	96104	GRATE - INNER	1	LIFETIME
9	96105	GRATE - OUTER	1	LIFETIME
10	96107	MANIFOLD	1	3
11	96106	GAS VALVE	2	1
12	96108	STAINLESS STEEL FLEX TUBE 16IN	2	1
13	96114	VENTURI TUBE BRASS FITTING	2	1
14	96109	IGNITOR WIRE 16.5IN	2	1
15	60032	INNER BURNER IGNITOR	2	1
16	96113	INNER BURNER BRASS CAP	1	1
17	96126	INNER BURNER VENTURI TUBE	1	1
18	96127	INNER BURNER VENTURE TUBE CAP	1	1
19	97128	INNER BURNER ORIFICE (LP ONLY)	1	1
20	97129	INNER BURNER ORIFICE (NG ONLY)	1	1
21	96115	HEAT SHIELD	1	1
22	96110	OUTER BURNER	1	3
23	96116	OUTER BURNER IGNITOR	1	1
24	95007	OUTER BURNER ADAPTER	1	1
25	96123	OUTER BURNER ORIFICE (LP ONLY)	1	1
26	96124	OUTER BURNER ORIFICE (NG ONLY)	1	1
27	16508	REGULATOR (LP ONLY)	1	1
28	96118	REGULATOR ADAPTER (LP ONLY)	1	1
29	96117	REGULATOR (NG ONLY)	1	1
30	96119	REGULATOR ADAPTER (NG ONLY)	1	1

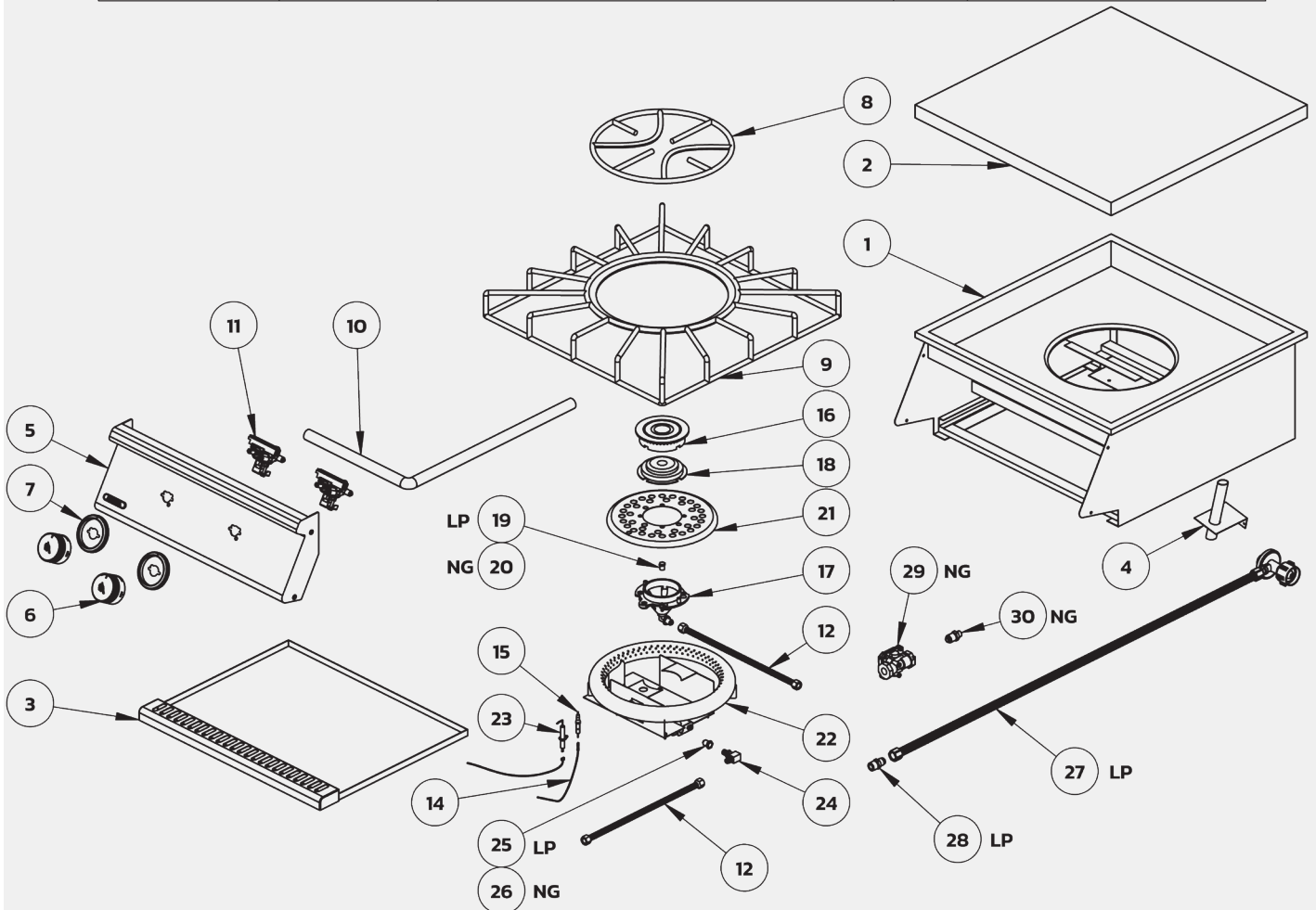

**WARNING:** Use of any part that is not factory authorized will void your warranty and may be dangerous.

## **Warranty Policy**

### **LIMITED WARRANTY ON BULL OUTDOOR PRODUCTS, INC., PRODUCTS**

**THIS LIMITED WARRANTY GIVES YOU SPECIFIC LEGAL RIGHTS. YOU MAY ALSO HAVE OTHER RIGHTS, WHICH VARY FROM STATE TO STATE.**

**THIS LIMITED WARRANTY CAN ALSO BE FOUND ON OUR WEBSITE AT:**

<https://www.bullbbq.com/support-warranty> (United States Customers)

<https://www.bullbbq.eu/customer-care/#warranty-registration-form> (International Customers)

**AND IN THE OWNER'S/INSTALLATION MANUALS THAT WE PROVIDE WITH OUR PRODUCT**

**THIS LIMITED WARRANTY IS SUBJECT TO THE EXCLUSIONS, CONDITIONS AND LIMITATIONS SET FORTH BELOW.**

**ANY IMPLIED WARRANTIES IMPOSED BY LAW, INCLUDING WITHOUT LIMITATION TO THE IMPLIED WARRANTIES OF MERCHANTABILITY AND FITNESS FOR A PARTICULAR PURPOSE, ARE LIMITED IN DURATION TO THE DURATION OF THIS EXPRESSED LIMITED WARRANTY. SOME STATES DO NOT ALLOW LIMITATIONS ON HOW LONG AN IMPLIED WARRANTY LASTS, SO THE ABOVE LIMITATION MAY NOT APPLY TO YOU.**

#### **WHO MAY USE THIS WARRANTY?**

**BULL OUTDOOR PRODUCTS, INC.** located at address 15 East Ave. Athens, TN 37303

("We") extend this limited warranty only to the consumer who originally purchased the product ("you") at the original site of delivery or installation. It does not extend to any subsequent owner or other transferee of the product. It does not extend to any rental, commercial, or non-residential application. Examples of excluded applications include, but are not limited to day care centers, schools, bed and breakfast centers, churches, private clubs, fire stations, club houses, Common areas in multi-family dwellings, restaurants, hotels, nursing homes, food service locations, and institutional food service locations.

#### **WHAT DOES THIS WARRANTY COVER?**

This limited warranty covers defects in materials and workmanship of the product and product components identified below for the Warranty Periods defined below.

#### **WHAT IS THE PERIOD OF COVERAGE?**

This limited warranty starts on the date of your purchase and lasts for the time periods specified on the next page. The Warranty Period is not extended if we replace the product. We may change the availability of this warranty at our discretion, but any changes will not be retroactive.

## Warranty Policy (Continued)

### Grilling/Pizza Accessories and Grill Covers DO NOT include a warranty period

#### Grill Warranty Periods

The following parts are covered for **1 year** on all our current gas grill models:

- The lid, control panel, grease tray, bezels, knobs, temperature gauge, valves, regulator, flex tubes, rotisserie burner, transformer, and all components of the lighting system.

The following parts are covered for **3 years** on all our current gas grill models:

- The manifold, handle end caps, flame tamers, heat shields, and warming rack.

The following parts are covered for the **Lifetime** on all our current gas grill models:

- Insert assembly and the grates.

The warranty period for the grill burners varies by type:

- Cast stainless steel burners – **Lifetime**
- Welded stainless steel burners – **5 years**
- Porcelain coated burners – **3 years**

The warranty period for the charcoal grill is **1 year** on all parts, except for the insert assembly, which is covered for **5 years**.

#### Component Warranty Periods

All the parts for our components /grill carts/refrigerators/kegerators/drawers/doors/refrigerator frames/grill

jackets/finishing frames/ice chest/sinks/bar center and vent hoods are covered for **1 year** with these exceptions:

##### • Power Burner

- o The insert/grates are **lifetime** covered parts.
- o The manifold/burner are covered for **3 years**.

##### • Searing Station/Slide in Double Sideburner

- o The grates are covered for **lifetime**,
- o The insert for **5 years**, and
- o The manifold for **3 years**.

##### • Single Sideburner

- o The grates are covered for **5 years** and
- o The burner for **3 years**.

##### • Sidekick

- o The burner is covered for **3 years**.

##### • Heaters

- o The heater replacement parts are covered for **3 years**.

##### • Pizza Ovens/Islands/Fire Features Warranty Periods

- o All of the parts and construction materials are covered for **1 year**.

## Warranty Policy (Continued)

### WHAT DOES THIS WARRANTY NOT COVER?

This limited warranty does not cover any damage due to:

- Transportation.
- Storage
- Improper installation or use.
- Use on improper fuel/gas supply.
- Failure to follow the product instructions or to perform any preventive maintenance.
- Modifications.
- Normal wear and tear, rust, corrosion, oxidation, or discoloration.
- External causes such as accidents, abuse, or other actions or events beyond our reasonable control.

### WHAT OPTIONS ARE OFFERED BY BULL OUTDOOR PRODUCTS UNDER THIS WARRANTY?

With respect to any defective product claim made during the Warranty Period, we will, in our sole discretion:

- Replace such product (or the defective part) free of charge.

### WHAT IS EXCLUDED BY BULL OUTDOOR PRODUCTS UNDER THIS WARRANTY?

- We will not pay for shipping charges for replacement parts, or for any labor or labor related charges.
- We will not pay for any accessory products or ancillary products purchased by you for use in connection with the product.

### HOW DO YOU NOTIFY BULL CUSTOMER SERVICE OF A POTENTIAL WARRANTY ISSUE?

**Our Customer Service is ready to help. Here's how to reach us:**



By Phone (800) 521-2855 Monday through Friday from 8:00 a.m. to 5:00 p.m. (EDT)



To submit a warranty, claim on-line or message go to <https://www.bullbbq.com/support-warranty.com>

### LIMITATION OF LIABILITY

**THE REMEDIES DESCRIBED ABOVE ARE YOUR SOLE AND EXCLUSIVE REMEDIES AND OUR ENTIRE LIABILITY FOR ANY BREACH OF THIS LIMITED WARRANTY. OUR LIABILITY SHALL UNDER NO CIRCUMSTANCES EXCEED THE ACTUAL AMOUNT PAID BY YOU FOR THE DEFECTIVE PRODUCT, NOR SHALL WE UNDER ANY CIRCUMSTANCES BE LIABLE FOR ANY CONSEQUENTIAL, INCIDENTAL, SPECIAL OR PUNITIVE DAMAGES OR LOSSES, WHETHER DIRECT OR INDIRECT.**

**SOME STATES DO NOT ALLOW THE EXCLUSION OR LIMITATION OF INCIDENTAL OR CONSEQUENTIAL DAMAGES, SO THE ABOVE LIMITATION OR EXCLUSION MAY NOT APPLY TO YOU.**

v2025.02.14